

DESCRIPTION: Model ACR-SEQ6-2009 power distribution panel with sequencer features nine NEMA outlets—six switched (controlled by power switch for sequential activation/deactivation) and three unswitched (always on). Outlets are clearly marked to assist the integrator with connections. The panel can also be activated and deactivated by a remote switch or alarm system that's connected to the plug-in barrier strip INPUT terminal blocks in the rear. In addition, there's an OUTPUT terminal block where remote power controls (RPCs) can be connected and controlled by this panel. RPC devices would occupy steps five and six in the sequence order.

The compact steel chassis with black powder epoxy finish is designed to occupy minimal rack space with overall dimensions of 19"W x 9"D x 1.75"H (1U). Termination is via an attached nine foot power cord with NEMA 5-20P plug.

FEATURES:

- **Outlets:** Unit features a total of nine 15A NEMA outlets, which are either switched (controlled by switch) or unswitched (always on).
 - Front Outlet: NEMA 5-15R (1 unswitched single)
 - Rear Outlets: NEMA 5-15R (2 unswitched single, 2 switched single, 2 switched duplex)
- **Activation & Sequencing:** Front rocker switch with momentary contacts (normally open SPST) plus rear barrier strip termination blocks for momentary (normally open) remote switches. Switch initializes the delayed start up sequence, activating the switched outlets in four steps, plus any remote power controls (RPCs) connected to the rear terminal block as steps five and six. A green LED flashes while the unit is powering up and holds steady when the cycle is complete. The switch also initializes the delayed shut down sequence, deactivating RPCs and outlets in reverse order. A red LED flashes while the unit is powering down and holds steady when the cycle is complete. Delay between steps can be adjusted with a screwdriver (0.5–10 seconds).

- **Connections for External Controls:** Plug-in barrier strip terminal block inputs in the rear of the panel allow external controls to activate and deactivate the switched outlets. The terminal block output allows this panel to control remote RPC units.

- **Left Terminal Block—input from Alarm System:** Lock On, Lock Off, and Switch Lock for alarm system or master control panel.
- **Center Terminal Block—output to Remote Power Control (RPC):** External RPC Series devices can be controlled when connected to the center terminal block. The connected RPCs would activate/deactivate as Steps 5 and 6.
- **Right Terminal Block—input from Remote Switch:** Connect a remote switch with momentary closure.

- **Power Rating:** 120VAC, 60Hz, 20A (outlets are 15A)
- **EMI/RFI Filter:** 19dB@500kHz, 42dB@30MHz
- **Circuit Breaker Protection:** 20A breaker with reset switch
- **Power Cord:** Attached 9-ft. cord with NEMA 5-20P plug
- **Chassis:** 19"W x 9"D x 1.75"H (1U), 11 lbs.
- **Certification:** ETL Listed in US/Canada (UL60065)
- **Country of Origin:** Made in the U.S.A. with global components

A&E SPECIFICATIONS: The rackmount power distribution panel with sequencer and remote power control circuitry shall be Lowell Model ACR-SEQ6-2009. It shall feature a total of nine NEMA 5-15R outlets (six switched in rear, two unswitched in rear, one unswitched in front) and a 20A circuit breaker. A rocker style switch in the front shall sequentially activate switched outlets in four steps, plus any remote power control devices connected to the rear terminal block as steps five and six (RPC Series, ordered separately). When pressed again, the switch shall deactivate devices and outlets in reverse order. Color coded LEDs on the front panel shall indicate sequencing status and the delay between steps shall be screwdriver adjustable (0.5 to 10 seconds). The panel shall have a power rating of 120VAC, 60Hz, 20A with EMI/RFI filtering. The 19"W x 9"D x 1.75"H (1U) steel chassis shall have a black powder epoxy finish. Termination shall be via an attached 9 ft. cord with NEMA 5-20P plug.

WIRING: Since switch functions are handled by low-voltage, low-current DC signals, almost any type of wire will work (CAT5, mic line, intercom wire, speaker wire, or phone wire). Shielding is not required but can be used.

Maximum wire distance: 24 ga.=20,000 ft., 22 ga.=31,200 ft., 18 ga.=76,800 ft.

CONNECTIONS for EXTERNAL CONTROLS: Plug-in barrier strip terminal block inputs allow external controls to activate and deactivate switched outlets. The terminal block output allows this panel to control remote RPC units.

• **LEFT TERMINAL BLOCK – Input from Alarm System (or Master Control Panel):**

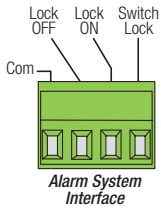

If required by local building code, facility usage, or the Fire Marshal, system switches can be overridden and the system controlled by contact closures provided by the fire alarm panel or another similarly installed device. A maintained contact between the 'Com' terminal and any of the terminals shown will provide the following functions. **CAUTION:** Do not allow alarm system to make more than one of the contacts described below at the same time—it could cause controller board damage

- **Lock OFF:** A maintained contact between the 'Com' terminal and the 'Lock Off' terminal will turn the system off and keep it off regardless of other switch activations. If the system is already off, it will be kept off.
- **Lock ON:** A maintained contact between the 'Com' terminal and the 'Lock On' terminal will turn the system on and keep it on regardless of other switch activations. If the system is already on, it will be kept on.
- **Switch Lock:** A maintained contact between the 'Com' terminal and the 'Switch Lock' terminal will lock the system in its current state, either on or off, regardless of any other switch activations.

• **CENTER TERMINAL BLOCK – Output to Remote Power Controls (RPC):**

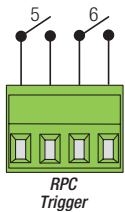

Connect Remote Power Controls to Output 5 and Output 6 in the center terminal block. The maximum number of RPC units that can be connected is 60 for each output, depending on limits of the electrical panel.

Note: Use RPC Series with classic connections. DO NOT use RPC-P Series with pass-through connections.

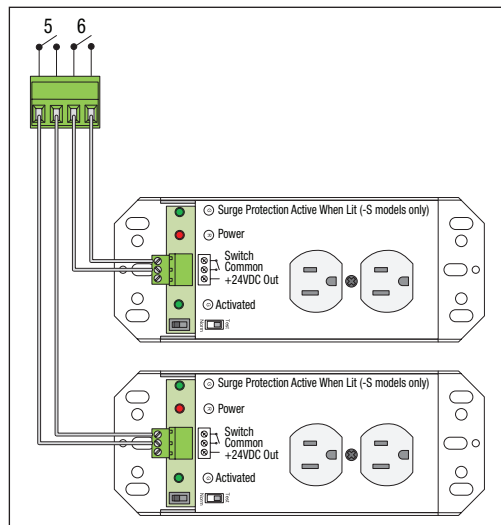

Wiring to remote power controls (RPC Series with classic connection)

• **RIGHT TERMINAL BLOCK – Input from Remote Switch:**

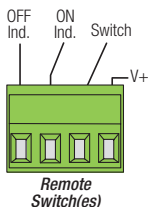

Connect remotely located momentary closure switch(es). Up to five switches can be utilized.

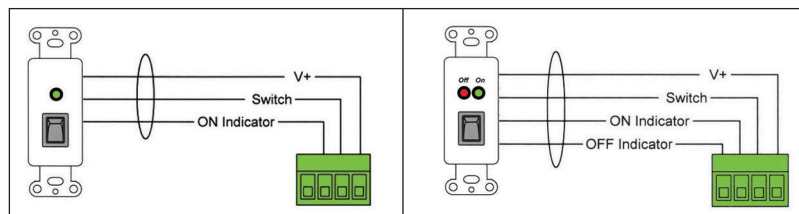

Wiring to momentary switch w/1 LED requires 3 conductors

Wiring to momentary switch w/2 LEDs requires 4 conductors



OPTIONS: (order separately)

- Lowell momentary closure switches:

<i>Model</i>	<i>Description</i>	<i>Model</i>	<i>Description</i>
RPSW-MP	1 LED rocker switch, white wall plate	RPSW2-MP	2 LED rocker switch, white wall plate
RPSB-MP	1 LED rocker switch, black wall plate	RPSB2-MP	2 LED rocker switch, black wall plate
RPSB-MR	1 LED rocker switch, 19" panel	RPSB2-MR	2 LED rocker switch, 19" panel
RPSW-MKP	1 LED key switch, white wall plate	RPSW2-MKP	2 LED key switch, white wall plate
RPSB-MKP	1 LED key switch, black wall plate	RPSB2-MKP	2 LED key switch, black wall plate
RPSB-MKR	1 LED key switch, 19" panel	RPSB2-MKR	2 LED key switch, 19" panel

- Compatible RPC Series remote power controls (classic connections only):

<i>Model Number</i>	<i>Description</i>
RPC-15	RPC with (2) 15A NEMA outlets
RPC-15-S	RPC with (2) 15A NEMA outlets, surge suppression
RPC-20-CD	RPC with (2) 20A NEMA outlets
RPC-20-SCD	RPC with (2) 20A NEMA outlets, surge suppression
RPC-3N1	RPC with (8) 15A NEMA outlets
RPC-20-HW	RPC with (2) 20A NEMA outlets, hardwired
RPC-20-SHW	RPC with (2) 20A NEMA outlets, surge suppression, hardwired

ACR Series Power Distribution Panels

<i>Model No.</i>	<i>Power Rating</i>	<i>Front Outlets</i>	<i>Rear Outlets</i>	<i>Surge Supp.</i>	<i>Power Input</i>	<i>Switch Type</i>	<i>Outlets Controlled by Switch</i>	<i>Network Interface</i>	<i>Charging Ports</i>	<i>Time Delay</i>	<i>Input from Remote Switch</i>	<i>Input from External Trigger</i>	<i>Input from Alarm System</i>	<i>Output to Remote Control</i>	<i>Lights</i>	<i>Country of Origin</i>
ACR-1505-SSI-RC	15A	1 (15A)	4 (15A)	yes	6' cord	---	---	yes	rear	---	---	---	---	---	---	USA
ACR-1506-LTS	15A	---	6 (15A)	yes	9' cord	rocker	all	---	---	---	---	---	---	hd	USA	
ACR-1507-GNLT	15A	1 (15A)	6 (15A)	---	9' det.cord	rocker	2	---	---	---	---	---	---	goose	USA	
ACR-1507-HDLT	15A	1 (15A)	6 (15A)	---	9' det.cord	rocker	2	---	---	---	---	---	---	hd-nt	USA	
ACR-1507-SSI-FC	15A	1 (15A)	6 (15A)	yes	6' cord	---	---	yes	front	---	---	---	---	---	USA	
ACR-1508-SHW	15A	---	8 (15A)	yes	6' conduit	---	---	---	---	---	---	---	---	---	USA	
ACR-1509-S	15A	1 (15A)	8 (15A)	yes	9' cord	rocker	3	---	---	---	---	---	---	---	China	
ACR-159-S	15A	1 (15A)	8 (15A)	yes	9' cord	rocker	all	---	---	---	---	---	---	---	China	
ACR-2009	20A	1 (15A)	8 (15/20A)	---	9' cord	rocker	5	---	---	---	---	---	---	---	USA	
ACR-209-S	20A	1 (20A)	8 (20A)	yes	9' cord	rocker	all	---	---	---	---	---	---	---	China	
ACR-RPC-1508-SD	15A	---	8 (15A)	yes	9' cord	ext	6	---	---	---	yes	yes	yes	---	USA	
ACR-SEQ4-1509	15A	1 (15A)	8 (15A)	---	9' cord	rocker & ext	6	---	---	SEQ	yes	---	yes	---	USA	
ACR-SEQ6-2009	20A	1 (15A)	8 (15A)	---	9' cord	rocker & ext	6	---	---	SEQ	yes	---	yes	yes	USA	

This spec

Surge Suppression = Panel includes basic surge suppression. (For rackmount panels with advanced surge suppression see ACSPR Series.)
Power Input = cord (attached cord), det.cord (detachable cord), conduit (non-metallic flexible conduit)
Switch Type (activation) = rocker (rocker switch on front), ext (external switch, not included)
Outlets Controlled by Switch = Number of outlets activated/deactivated by switch. Other outlets are unswitched (always on).
Network Interface = Panel includes network pass-through ports.
Charging Ports = Panel includes high speed charging connectors for devices (USB-A, Type-C)
Time Delay (SEQ) = Panel includes sequencing to activate/deactivate switched outlets with a time delay between steps (adjustable).
Input from Remote Switch = Panel can be controlled by an external switch, typically placed in a remote location (order RPS Series switch separately).
Input from External Trigger = Panel can be controlled by external trigger voltage (separate control system by others, not included).
Input from Alarm System = Panel can accept control override from an alarm system (alarm by others, not included).
Output to Remote Control = Panel can activate/deactivate remote equipment (order RPC Series remote power controls separately).
Lights = hd (hooded white light), goose (gooseneck lights), hd-nt (hooded night-vision lights)
 See individual product spec sheets for more information.

