



**INSTALLATION:** Recessed  
**FOR SPEAKER SIZE:** 8" EIA  
**FOR GRILLE TYPE:** Screw-mount or torsion

Recessed steel enclosure with black finish is made for use with screw-mount or torsion grilles and 8" speakers.

### FEATURES:

- **Construction:** Welded unitized 22-gauge certified U.S. steel with black powder epoxy finish
- **Diameter:** 10.06" can dia. (11.874 overall)
- **Depth:** 4.06"
- **Volume:** 0.187 cu.ft.
- **Knockouts:** Four combination knockouts for conduit (1/2"–3/4"); four knockouts for wire (1/2")
- **Acoustic Lining:** Foam pad in bottom
- **Installation:**
  - Welded receptacles will accept torsion grilles for a hardware-free appearance
  - 8-32 U-clips will accept screw-mount grilles
  - Grille mounting bolt circle 11.25" dia.
- **Country of Origin:** Made in U.S.A.
- **A&E Specifications:** The recessed enclosure for torsion or screw-mount grilles and 8" speakers shall be Lowell model XCP84, which shall be certified U.S. steel with black powder epoxy finish with 10.06" can diameter and 4.06" depth. It shall feature four (1/2"–3/4") compound knockouts for conduit, four (1/2") knockouts for wire, and a foam pad liner in the bottom. It shall be made in the U.S.A.

### COMPATIBLE COMPONENTS: (order separately)

- **Drivers:** 8" EIA. Enclosure is not for use with Lowell driver model 8A50 or 8P100.
- **Driver+Grille Assemblies:** C1830-870, R1810-72, R1810-72K, R1810-72S, RT1810-72
- **Grilles (screw-mount):** A8-AW, CS-8H, LO8-P, RS8-AW, WB-8
- **Grilles (torsion):** CN-8M, WB-8T. Torsion grilles accept maximum driver/transformer weight of 3.5 lbs. (typically a driver with up to 10 oz. magnet).
- **Tile-bridges:** LBS8-R1, LBS8. When installed in a suspended tile ceiling, T-bridge LBS8-R1 is recommended to transfer the weight of the speaker assembly to the ceiling grid (8-32 screws to be provided by installer). T-bridge model LBS8 can also be used.

### XCP Series Summary

Model No.	For Speaker Size	Diameter	Depth	Volume (cu.ft.)	Undercoating	Lining	Conduit Knockouts	Wire Knockouts	Straps
▶ XCP84 †	8"	10.06"	4.06"	0.187	---	foam pad	4	4	---
XCP84-S †	8"	10.06"	4.06"	0.187	---	foam pad	4	4	2
XCP87 *	8"	10.06"	6.69"	0.308	---	1-1/2" batting	4	4	---
XCP810	8"	10.06"	10.06"	0.463	---	1-1/2" batting	4	4	---
XCP1210 **	12"	14.375"	10"	0.9	---	1-1/2" batting	4	---	---

† Note depth of driver to check fit and consider better bass response may be obtained by using an enclosure with greater depth.

\* When driver/grille WB8-8A50-T870 is used with enclosure XCP87 the assembly is UL Listed (UL1480 5th edition general signaling, UL2043 for use in plenum space).

\*\* Overall depth with rear stiffening bracket is 10.5". The XCP1210 is not for use with Lowell driver model 12Q250.



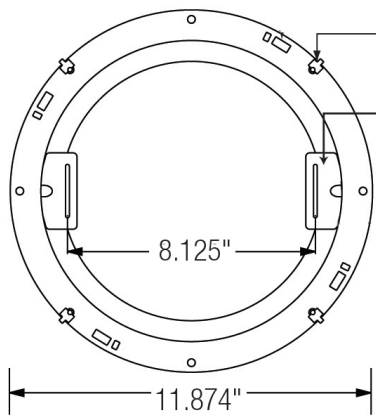

8-32 U-clips  
for screw-mount grille

Welded torsion receptacles  
for torsion grille

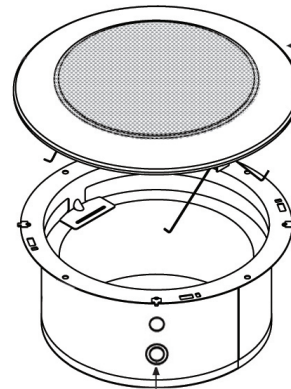

Torsion grille  
(order separately)

Knockouts –  
1/2"-3/4" for conduit  
1/2" for wire

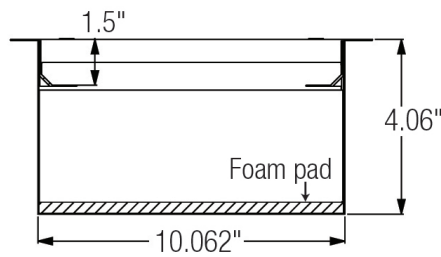

Grille mounting bolt circle: 11.25" dia.

