

Model: LMB (F-series)

Lowell Mobile Base with fine-floor Casters

Description:

The LMB (F-series) mobile base is designed to mount inside the rack frame to provide the benefits of mobility plus a floor that's positioned flush to the bottom rack space. This model is often specified to support extra-heavy equipment that's mounted in the lowest rack position. Construction is 14-gauge steel with a durable black wrinkle powder epoxy finish. To facilitate cable access, there is a center opening in the bottom and side openings that correspond to side openings on matching gangable racks (LGR-series). The base features (4) non-locking heavy-duty swivel casters positioned inside the platform. Casters feature a specially formulated rubber tread that won't mar fine floors. Each caster has a load rating of 200 lbs. (800 lbs. total). When the base is installed in a rack the increase in overall rack height is only 1.5".

Note: The mobile base is not for use with seismic-certified racks.

Features:

- Rugged, fully-welded construction
- For use with 19" wide racks (LER, LER-F and LGR-series)
- Easy cable access through center and side openings
- Includes (4) non-locking 3" swivel casters with a load rating of 200 lbs. each (800 lbs. total).
- Casters have a specially formulated rubber tread that won't mar fine floors
- Includes hardware for bolt-on installation
- Available in four depths: 27", 32", 36", 42"
- Increases rack height 1.5"

A & E Specifications:

The mobile base for the rack shall be Lowell Model No. _____, which shall be of an inner platform design that mounts inside the rack frame to add the benefits of mobility plus a floor positioned flush to the bottom rack space. Construction shall be 14-gauge welded steel with a black wrinkle powder epoxy finish. The heavy-duty 3" non-locking swivel casters shall be positioned inside the base, increasing overall rack height by 1.5". The casters shall have a load rating of 200 lbs. each (800 lbs. total) and shall feature a specially formulated rubber tread that won't mar fine floors. The mobile base shall facilitate cable access through a center opening and side openings that correspond with side openings on matching gangable racks (LGR-series). Mounting hardware to attach base to the rack shall be supplied with the base.



The base features casters with a specially formulated rubber tread that won't mar fine floors.



Model No.	Description	Overall Size (W x D x H)	Inside Size (W x D)	Center Opening (W x D)	Weight (lbs.)
LMB-27F	Mobile Base with fine-floor casters (for 27"D rack)	22.81" x 26.75" x 3"	19.81" x 22.75"	12.97" x 11.00"	28
LMB-32F	Mobile Base with fine-floor casters (for 32"D rack)	22.81" x 31.75" x 3"	19.81" x 27.75"	12.97" x 16.00"	31
LMB-36F	Mobile Base with fine-floor casters (for 36"D rack)	22.81" x 35.75" x 3"	19.81" x 31.75"	12.97" x 20.00"	38
LMB-42F	Mobile Base with fine-floor casters (for 42"D rack)	22.81" x 41.75" x 3"	19.81" x 37.75"	12.97" x 26.00"	37

Model: LMB (F-series)

Lowell Mobile Base with fine-floor Casters

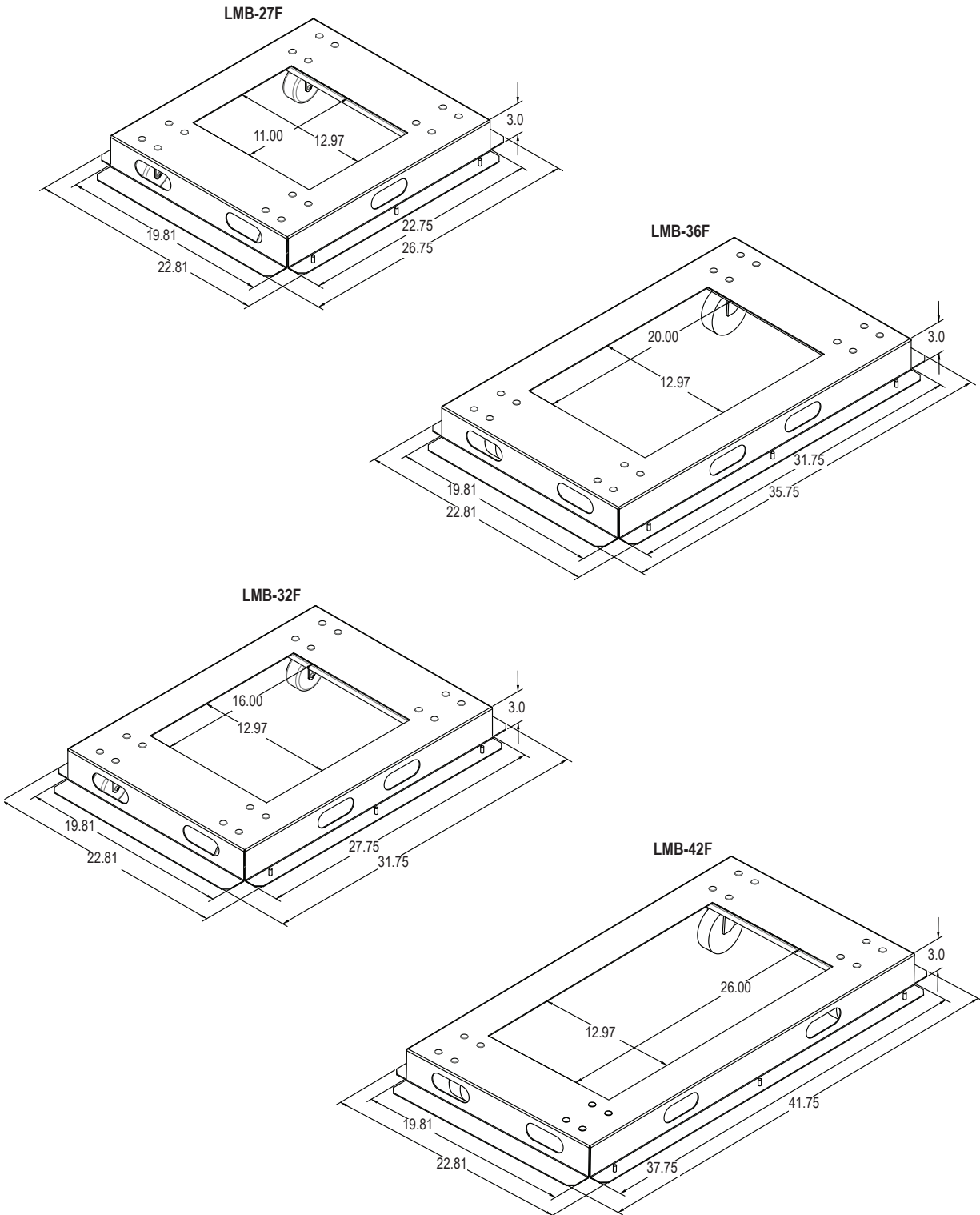

All measurements are inches.