

19" Rackmount Sequencer (8-step) – Low Voltage

Description:

Lowell rackmount sequencer Series SCS8R-ASM provides time delayed activation and de-activation of equipment with standard full sequence capability or Alternate Sequence Mode (ASM). Unique Alternate Sequence Mode provides the opportunity to bypass selected outputs for alternate applications such as regularly scheduled rehearsals and other events where all sequenced equipment is not necessary. As with other Lowell sequencers, Series SCS8R-ASM is typically utilized in conjunction with Lowell's Remote Power Control Series RPC which is available in rackmount or vertical strip styles and with Lowell's RPS Series switches. Slim, 1U sequencer sequentially activates equipment that is connected in the same rack or in remote locations. Sequence operation is initiated by a front rocker switch in Model SCS8R-ASM or key switch in Model SCS8RK-ASM. Clearly marked and color coded LED's provide visual status of connected equipment and a front adjustable delay allows 0.5-10 seconds between steps. Steel chassis is 19"W x 1.75"H (1U) x 9"D with black powder epoxy finish. Includes UL Listed 18VAC power supply.

Features:

- Low voltage power sequencer with 8 steps and capability to program an alternate step sequence.
- Sequential power control allows connected equipment to be turned on/off in time delayed order - up to 8 steps.
- Integral override facilitates use in life safety applications where fire code mandates an alarm interface.
- Rocker-switch or key-switch activation.
- Made in the U.S.A.

Rear controls: The rear of the unit features eight barrier strip control outputs, a rear programmable dip switch for alternate sequence operation, and an alarm interface for use where required by local building code. Each of the eight control outputs include switch contacts for connection to remote power control-activated equipment and auxiliary dry contacts for the sequential activation of accessory systems such as projector screens, lighting, blinds, etc. To sequentially activate RPC connected equipment, each switch output contact (common, switched relay) is connected via 2 conductors to an RPC Series remote power control (order separately) and then to the equipment to be sequentially activated. Note: Each output can be connected to one remote power control with a single piece of equipment or up to ten remote power controls, in daisy chain format, with multiple pieces of equipment each. To sequentially activate accessory systems and/or indicator devices, each control output includes auxiliary contacts (normally closed, common, normally open) with a rating of 5A for connection to peripheral devices.

Remote Switches: Optional switches for remote activation of the sequencer (instead of front rocker or keyswitch) may be connected to the terminal block on the rear panel. Up to 8 switches may be connected in parallel (see page 2).

Alternate Sequence Mode: To utilize the sequencer in Alternate Sequence Mode whereby selected outputs are bypassed for partial system operation, two things must be done. First the 'Sequence Step Bypass' termination block on the rear panel needs to be set on or off for each of the eight steps. Additionally, a separate ASM-style remote switch (order separately) needs to be installed to activate the alternate sequence operation. Note: The dry contact may also be activated using devices by others including Crestron and AMX.

Note: Switches to control the full sequence and alternate sequence operations may be installed side by side in decora-style wall plates or in Lowell's LD Series rackmount device panels for decora-style devices.

Model: SCS8R-ASM



A & E Specifications:

Device for sequentially activating equipment shall be Lowell rackmount Model _____ (SCS8R-ASM, SCS8RK-ASM). Device shall feature front mounted actuation switch _____ (rocker or key) style, front mounted LED's and front accessible trim pot for delay adjustment of sequence operation. Rear panel shall feature eight barrier strip terminals for remote power control units plus dry auxiliary contacts for accessory devices. It shall also have a separate alarm interface connection and dip switch settings to bypass selected outputs. Equipment to be controlled shall be connected to the sequencer using 2 conductor wire and Lowell's remote power control Series RPC (required, order separately). The rear panel shall also include contacts for connecting an optional momentary style switch _____ (Series RPSW-M, RPSB-M) for remote full sequence operation of the sequencer controller and contacts for optional maintained style ASM switch _____ (RPSW-KP-ASM, RPSB-KP-ASM) to control alternate sequence operation. Remote power control for use with Lowell sequence controllers shall be Lowell Model _____.

Specifications:

Power Required:	117VAC, 60Hz, 16W
Termination:	UL Listed 18VAC power supply.
Actuation Switch:	Front panel rocker or key switch with momentary contacts (normally open SPST) plus rear barrier strip termination blocks for momentary (normally open) remote switches.
Delay between steps:	0.5 - 10 seconds (front screwdriver adjust)
Front Panel LED's	Red, Green and Yellow LED's with labeling indicate system status
External Control Connections:	Barrier strip terminal blocks
Auxiliary Contacts:	8 switched barrier strip dry contacts. (5A max). Each switch contact controls up to ten RPC Series remote power controls each.
Alarm Interface:	Lock on, lock off and switch lock functions for alarm system or master control panel applications.
Remote Switch Contacts	Single terminal block connects up to 8 momentary switches in parallel to activate sequencer from a remote location.
Dip Switch for ASM	Allows specified steps to be bypassed. Requires ASM Switch accessory
Chassis construction:	Steel with black powder epoxy paint finish.
Dimensions / weight:	19"W x 1.75"H (1U) x 9"D / 12 lbs.
Optional Accessories:	
Remote Power Controls	RPC Series
Remote Switches:	RPS Series
ASM Switch	RPSW-KP-ASP or RPSB-KP-ASP

Model	Description	Power Required	On/Off Switch
SCS8R-ASM	Low voltage sequencer-8 Channel (1U) Rocker Switch - ASM	117VAC, 60Hz, 16W	Rocker
SCS8RK-ASM	Low voltage sequencer-8 Channel (1U) Key Switch - ASM	117VAC, 60Hz, 16W	Key

19" Rackmount Sequencer (8-step) – Low Voltage

Red LED
FLASHING = Down cycle in progress.
STEADY ON = Down cycle completed (system off).

Green LED
FLASHING = Up cycle in progress.
STEADY ON = Up cycle completed (system on).

Yellow LED- Alternate Sequence Mode activated



Actuation Switch
Starts sequence up or down.
Activation in in mid-cycle reverses direction of cycle.
Switch Style: Rocker = SCS8R-ASM, keylock = SCS8RK-ASM

Green LED's- Indicate progress of UP and DOWN sequence

Delay - Recessed trim pot with screwdriver adjust.

8 Auxiliary Dry Contacts*

Normally Closed
Common
Normally Open

* May be used to control other systems (projector screens, lighting, blinds, etc) or indicators. - contact rating is 5A max.

8 Switch Contacts for Remote Power Controls*

*Up to 10 Remote Power Controls (RPC) units can be controlled by each sequencer step. Note: common connections from multiple remote RPC units (controlled by different sequence steps) can be consolidated into one conductor and connected to any common terminal at the sequencer.

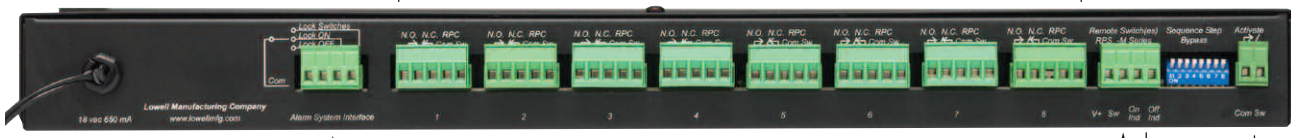

Includes UL Listed 18VAC
650 mA Power Supply

Alarm System Interface

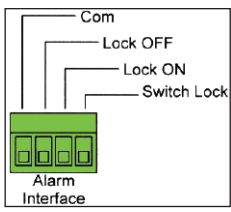

If required by local building code, facility usage, or the Fire Marshal; the system switches can be overridden and the system controlled by contact closures provided the fire alarm panel or other similarly installed device. A maintained contact between the 'com' terminal and any of the terminals shown will provide the following functions.

Lock Off: A maintained contact between the 'com' terminal and the 'lock off' terminal will turn the system off and keep it off regardless of other switch activations. If the system is already off, it will be kept off.

Lock On: A maintained contact between the 'com' terminal and the 'lock on' terminal will turn the system on and keep it on regardless of other switch activations. If the system is already on, it will be kept on.

Switch Lock: A maintained contact between the 'com' terminal and the 'switch lock' terminal will lock the system in its current state, either on or off, regardless of any other switch activations. Note: Switch lock function is overridden by External Trigger voltage.

Caution: Do not allow alarm system to make more than one of the above described contacts at the same time. Controller board damage may result.

Remote Switch(es)

Optional - up to 8 momentary switches may be connected in parallel.

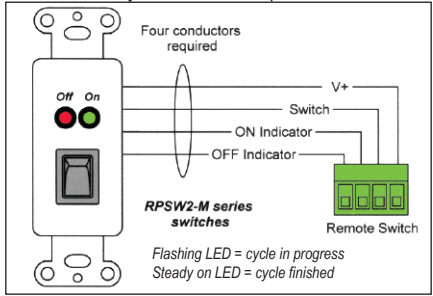

Momentary Switches with 2 LED's
Wallplate Series RPSW2-MP (white), RPSB2-MP (black), 1RU panel Model RPSB2-MR

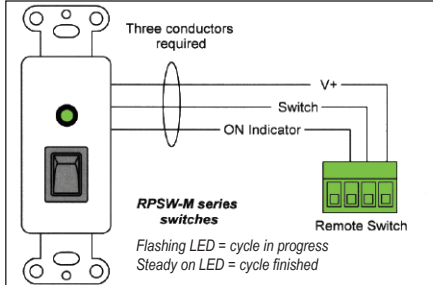

Momentary Switches with 1 LED
Wallplate Series RPSW-MP (white), RPSB-MP (black), 1RU panel Model RPSB-MR

Maximum wire distances
24ga.: 20,000 ft. (approx. 3.5 miles), 22ga.: 31,200 ft. (approx. 5.5 miles), 18ga.: 76,800 ft. (approx. 13.5 miles)

Alternate Sequence Mode (ASM)

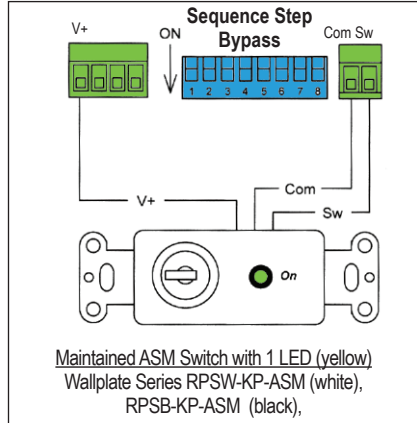

Alternate Sequence Mode (ASM) allows for the bypassing of selected outputs for partial system operation (rehearsals, small events, etc.).

The easy-to-use bypass on the rear of the unit is a programmable DIP switch (See **Sequence Step Bypass** above). Choose steps to be bypassed and set the corresponding DIP switches. When contact closure is applied between 'Com' and 'Sw' the chosen steps will be skipped.

Remote switching in Alternate Sequence Mode requires a special keystone switch Model RPSW-KP-ASP (white) or RPSB-KP-ASP (black). Note: Systems can include both an ASM switch and a standard remote switch mounted separately or side by side.

