

Description

Lowell grille Model CN-8M is an attractive ceiling grille that satisfies architectural specifications requiring ceiling speakers to be void of visible mounting hardware. Model CN-8M grille presents a precision quality appearance with a contoured outer ring, fine-mesh interior and no visible hardware. The grille utilizes specially designed torsion devices to mount into torsion receptacles that are welded into companion Lowell backbox Series IX6 (order separately). Grille is perfect for 6.5" speaker installations in upscale offices, hotels, retail, professional buildings, and dining establishments.

The outer ring of Model CN-8M is formed from 20-gauge steel with a welded steel mesh center, an inner ring with welded speaker studs and white powder epoxy finish for long lasting quality appearance.

The grille includes two easy-to-install torsion bracket/spring devices that are used to mount the grille to backbox Series IX6 after the 6.5" driver is direct-mounted to the backbox. This direct mount method of screwing the speaker into the recessed flange of the backbox removes the load bearing requirements from the grille allowing heavier and typically higher quality speakers such as Lowell's 6A40 Series (40W) to be used with a hardware free grille.

Each torsion bracket installs to opposite mounting studs (as shown) with 8-32 nuts provided. Each torsion spring installs to one of four holes in the bracket (as shown) with one shoulder bolt and clip provided. Versatile spring position on the bracket allows for easy depth adjustment.

Note: This grille is also used for installation of 8" speaker drivers. Please refer to the 8" speaker section for companion 8" speaker mounting accessories.

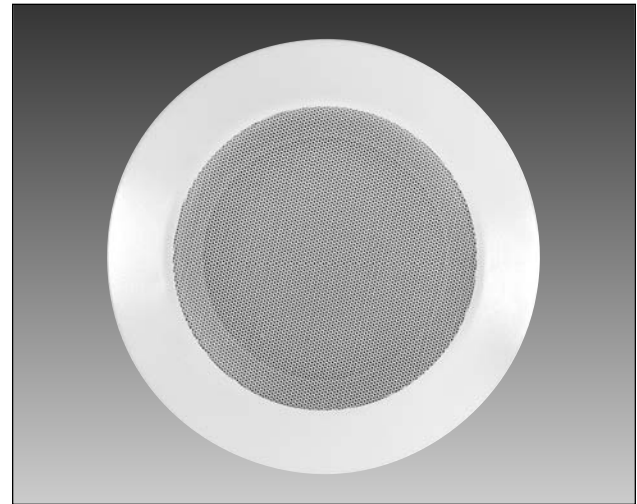

CN-8M
Steel grille with torsion mount for visibly hardware-free appearance

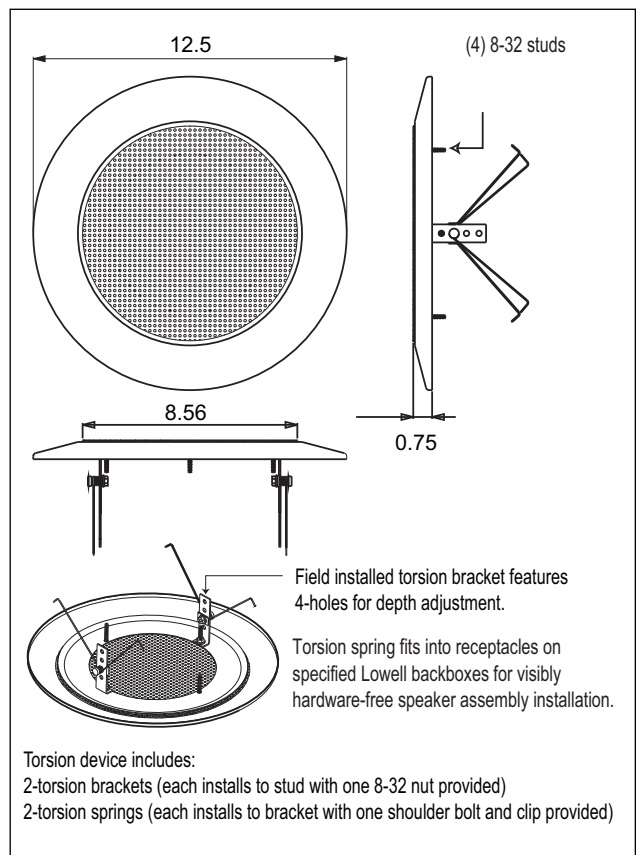

Grille Specifications and Companion Mounting Accessories (order separately)

Grille Model	Speaker Size*	Grille Size	Visible Screws	Speaker Mount	Material	Color	Backbox (order separately)	+	T-Bridge or Rails (order separately if required for suspended ceilings)
CN-8M	6.5"	12.5" Dia.	0-Torsion**	None**	Steel	White	IX610 (flat flange for tile ceilings) IX610-EL (extended lip for drywall/plaster ceilings)...	LBS8-R1 SS-24 rails

*Grille also mounts 8" speakers with different companion backboxes. See 8" speaker section.

**IX6 Series backboxes direct mount the speaker so that the grille is non-load bearing.



CN-8M

Architectural Grille with Torsion-mount for 6.5" Speakers

A
U
D
I
O

A & E Specifications

The grille for 6.5" speaker drivers shall have no visible screws or hardware and shall be Lowell Model CN-8M. It shall be fabricated from 20-gauge steel with a welded steel mesh center and mount using torsion bracket/spring devices. The grille diameter shall be 12.5" with a shallow mounting projection of 0.754". The grille shall be finished in white powder epoxy.

Model CN-8M shall include two torsion bracket/spring devices and installation accessories for mounting to specified Lowell backbox with torsion receptacles. The torsion/bracket shall be adjustable for varying ceiling depths.

The 6.5" speaker used with CN-8M grille shall NOT mount to the grille but shall direct/screw mount to backbox Model IX610 or IX610-EL. Model CN-8M grille, without the weight of a speaker/transformer, shall then mount to the torsion receptacles in the backbox.

Companion backbox with torsion receptacles shall be Lowell Model IX610 with flat mounting flange for tile ceilings or Model IX610-EL with extended lip for plaster or drywall ceilings. For installations where the speaker assembly weight needs to be transferred to the ceiling structure, tile bridge Model LBS8-R1 or channel rail Model SS24 shall be specified.

12"10"
Speakers &
Accessories

8"
Speakers &
Accessories

Companion Accessories for Grille Model CN-8M when used with 6.5" Speaker (Order Separately)



IX610



LBS8-R1



SS-24

Backbox Details

Model	Size	Features
IX610	10.063"Dia. x 10.063"D	Direct-mts 6in spkr, flat flange for tile ceiling, batting, t-receptacles
IX610-EL	10.063"Dia. x 10.063"D	Direct-mts 6in spkr, ext lip flange for drywall, batting, t-receptacles

**Backbox Series IX6 will mount Lowell's Model 6A40 or other EIA 6.5" drivers. Transformers may be driver mounted or supported by the rear coverplate.*

6"
Speakers &
Accessories

Tile Bridge or Channel Rail Details (use if required for suspended ceiling)

Model	Size	Features
LBS8-R1	23.75"L	10.75"Dia opening with screw or Twist n' Lock backbox mounting
SS-24	23.75"L	Galvanized steel rails (pair) with 4 mounting screws

4"
Speakers &
Accessories

Horn
Speakers &
Accessories

Masking
Speakers &
Generators

Control
Accessories
& Electronics

Grilles - Ceiling / Wall