

**Description**

Lowell grille Model WB8-6 is an economical steel ceiling grille for 6.5" loudspeakers. The clean, contoured edge appearance and low cost makes it popular for installation in offices, hotels, schools, medical, retail, and commercial facilities of all kinds.

Additionally, the grille is the same diameter and mounts the same backboxes as the industry standard 8" grille model WB8. This allows the contractor to standardize on one backbox while using 8" and 6.5" speakers in various areas throughout a project.

Model WB8-6 is precision formed from a single piece of 22-gauge steel with a perforated center and beveled edge for attractive ceiling installation. Model WB8-6 features 8-32 x 1" welded studs with palnuts for concealed mounting of an E.I.A. 6.5" speaker. It is equipped with four white 8-32 x 1-1/2" Phillips-head screws for attaching the speaker-grille assembly to the backbox or mounting ring (order separately - see page 2). The grille is finished in white powder epoxy for long lasting quality appearance.

Lowell offers a high quality coaxial speaker Model 6A40 (40W) with optional 70V transformer for distributed voice paging and music. See specifications for detailed performance data. Order speaker separately.

**A & E Specifications**

The grille for 6.5" speaker drivers shall be Lowell Model WB8-6. It shall be fabricated one-piece 22-gauge steel reinforced with a peripheral flange of 60 degrees. The grille diameter shall be 12.875" with a shallow mounting projection of 0.25". Model WB8-6 shall include welded studs for mounting specified 6.5" speaker. Each grille shall also have four 0.25" holes spaced at 90 degree intervals on a 11.25" bolt circle for mounting specified backbox or mounting ring. Models shall be finished in white powder epoxy and include four white 8-32 x 1-1/2" Philips-head screws for backbox mounting. Companion backbox or mounting ring shall be Lowell Model \_\_\_\_\_. Companion tile bridge or channel rails for suspended installations shall be Lowell Model \_\_\_\_\_.



**WB8-6**

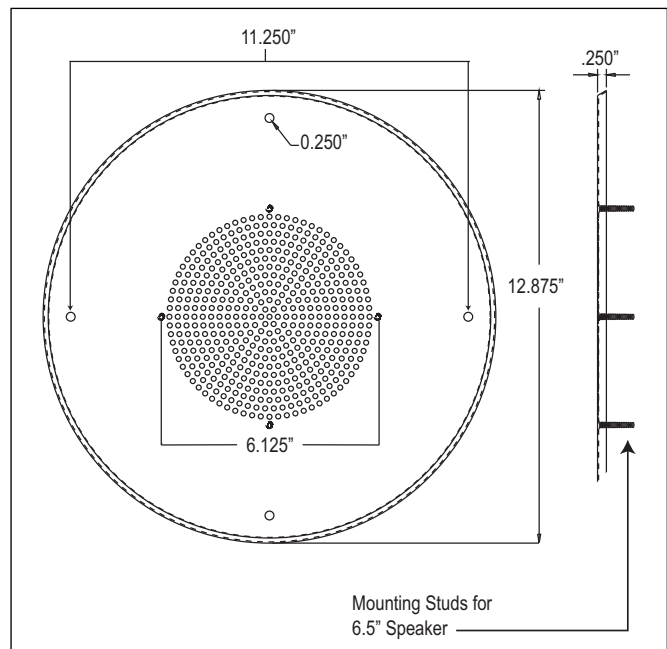

**WB8-6 Specifications**

**Grille Specifications and Companion Mounting Accessories** (order separately)

Grille Model	Speaker Size*	Grille Size	Mounting Provisions	Material	Color	Backbox or Mtg. Ring Choices (Choose one, plus tile bridge or rails if required.)	T-Bridge or Rails (if required for suspended ceilings)
<b>WB8-6</b>	6.5" Speaker	12.875" Dia.	4 screws	Steel	White	CP87, CP810, DX58, DX108 ..... XCP87, XCP810, RF871 .....	LBS8-CP or SS Rails LBS8 or LBS8-R1

\*Order Lowell's popular coaxial 6.5" speaker Model 6A40 (40W) separately.



CP810



CP87



DX108



DX58



XCP810



XCP87

**Backbox Details** (Choose one backbox or mounting ring, plus tile bridge or rails if required)

Model	Size	Features
CP87	11.938" Dia. x 6.687"D	Extended lip for sheetrock + batting
CP810	11.938" Dia. x 10.063"D	Extended lip for sheetrock + batting
DX58	11.938" Dia. x 8"D	.5 cu.ft., Extended lip + batting
DX108	15" Dia x 10.125"D	1 cu.ft., Extended lip + batting
RF871	10.063" Dia. x 6.688"D	Retrofit w tension brkt.
XCP87	10.063" Dia. x 6.687"D	Flat flange for tile ceiling + batting
XCP810	10.063" Dia. x 10.063"D	Flat flange for tile ceiling + batting

**12" / 10"**  
Speakers &  
Accessories

**8"**  
Speakers &  
Accessories



PR8-1624



RMP8

**Mounting Ring Details** (Choose one backbox or mounting ring, plus tile bridge or rails if required)

Model	Size	Features
PR8-1624	13.25" Dia with ears	Extended lip for sheetrock plus mounting ears for 16" & 24" studs, steel
RMP8	13.813" Dia.	Plastic - use for retrofit

**6"**  
Speakers &  
Accessories

**4"**  
Speakers &  
Accessories

**Horn**  
Speakers &  
Accessories

**Masking**  
Speakers &  
Generators

**Control**  
Accessories  
& Electronics



LBS8-CP

LBS8

LBS8-R1

**Tile Bridge Details** (use tile bridge or rails if required for suspended ceiling)

Model	Size	Features
LBS8-CP	23.75"L	Requires noted backbox
LBS8	23.75"L	8.5" SQ opening with screw or Twist n' Lock backbox mounting
LBS8-R1	23.75"L	10.75" Dia opening with screw or Twist n' Lock backbox mounting



SS Series

**Channel Rail Details** (use tile bridge or rails if required for suspended ceiling)

Model	Size
SS-24	23.75"L
SS-30	30"L
SS-48	47.75"L