

# iMount™ 100W Speaker System

## Description

iMount™ Speaker systems provide specifiers and systems integrators with versatile packaged solutions for high performance suspended speaker installations. Model Group IMC8P features Lowell's 8" speaker Model 8P100 (100W) mounted in to a cylindrical 2 cu.ft. acoustic enclosure with installed 1/4" - 20 forged eyebolts and round architectural grille. Ready-to-install systems are painted black (B) or White (W) and feature externally accessible speaker connections and 20/20 AudioVision™ transformer (noted models) for superior music fidelity in distributed applications. Systems are ideal for high energy, high ceiling applications such as clubs and sports bars, hotel ballrooms, educational and government multi-purpose areas, convention and sporting facilities, airport terminals and transportation concourses.

## Features:

- Packaged solution for high performance suspended speaker installations.
- 100W system reproduces music with exceptional quality for improved customer satisfaction.
- Installation is fast and easy with premounted eyebolts and externally accessible connections.
- Optional 20/20 AudioVision™ transformer for distributed applications.

## System Components:

The 8-ohm 8P100 driver features a robust motor structure with 38oz. magnet, 2" voice coil, and coaxially mounted compression driver tweeter for high power handling with excellent efficiency. The driver is mounted into the enclosure with terminations accessible through a top mounted 4" x 4" cover plate.

For 70V distributed applications transformer Model TLS10070 (100W) or TLS3270(32W) is included in select models. Each transformer features a front mounted tap selector switch with convenient access through the grille and is part of Lowell's exclusive 20/20 AudioVision™ Series offering true 20Hz - 20kHz performance. *Note: 20/20 AudioVision™ Transformers have full frequency response and high power handling which allows the speaker to operate at full potential while providing a stable load to the amplifier. The resulting benefit is that 20/20 AudioVision™ Transformers allow a distributed speaker system to sound imperceptibly the same as a "transformerless" direct to voice coil system with the advantages of easier wiring layout, less expensive wire, and reduced labor cost.*

Cylindrical enclosure is precision-formed steel with 1-1/2" thick premium acoustic lining, and forged 1/4" - 20 eyebolts screwed into riveted mounting nuts for secure suspended installation using flyware by others. The enclosure and steel grille assembly is finished in Lowell's durable powder epoxy in black (B) or white (W).

Systems are shipped one per carton with the grille mounted to protect the driver. The transformer selector switch is accessible through an opening in the grille.



**2 cu.ft. Assembly**

Each ready-to-install assembly includes:

- 2 cu.ft. acoustic enclosure in black (B) or white (W)
- 100W speaker Model 8P100 (8-ohm)
- 70V-32W or 70-100W transformer (noted models)
- 1/4 x 20 forged eyebolts
- Wiring terminated through a 4" x 4" flush cover plate



**Speaker**  
8P100



**Transformer**  
(32W or 100W noted models only)



Also available  
in white

## A&E Specifications

The speaker for suspended installation shall be Lowell iMount system Model IMC8P-\_\_\_\_\_ with 8" 100W driver Model 8P100 mounted into a cylindrical enclosure with a volume 2 cu.ft., installed forged eyebolts, and steel architectural grille. Assembly shall be finished in \_\_\_\_\_ (black, white).

Frequency response of the iMount™ system shall be 48Hz - 20kHz±9dB with average sensitivity of 94dB. Dispersion shall be 90 degrees @ 2000Hz measured 6dB down. Overall dimensions shall be 21"H x 15.125"Dia. System driver Model 8P100 shall have a 38oz magnet, 2" voice coil, and coaxially mounted compression driver tweeter. For distributed applications, the driver shall include a wired 70V 100W transformer Model \_\_\_\_\_ (TLS10070) or 32W transformer Model \_\_\_\_\_ (TLS3270). Transformer tap selections shall be adjustable on the front of the assembly. System enclosure shall be welded steel construction with 1-1/2" thick acoustic lining. It shall have forged 1/4" - 20 eyebolts screwed into riveted mounting nuts for suspended installation using flyware by others.

Model No.	Description	Volume	Speaker	Transformer (70V)	Enclosure & Grille Color	Mtg Hardware	Weight lbs.
IMC8P-2B	iMount 100W Packaged Speaker System	2 cu.ft.	8P100	---	Black	(3) 1/4" - 20 forged eyebolts	24
IMC8P-2W	iMount 100W Packaged Speaker System	2 cu.ft.	8P100	---	White	(3) 1/4" - 20 forged eyebolts	24
IMC8P-TS100-2B	iMount 100W Packaged Speaker System	2 cu.ft.	8P100	TLS10070	Black	(3) 1/4" - 20 forged eyebolts	30
IMC8P-TS100-2W	iMount 100W Packaged Speaker System	2 cu.ft.	8P100	TLS10070	White	(3) 1/4" - 20 forged eyebolts	30
IMC8P-TS32-2B	iMount 100W Packaged Speaker System	2 cu.ft.	8P100	TLS3270	Black	(3) 1/4" - 20 forged eyebolts	28
IMC8P-TS32-2W	iMount 100W Packaged Speaker System	2 cu.ft.	8P100	TLS3270	White	(3) 1/4" - 20 forged eyebolts	28

# iMount™ 100W Speaker System

## IMC8P-series ship wired and ready for installation!

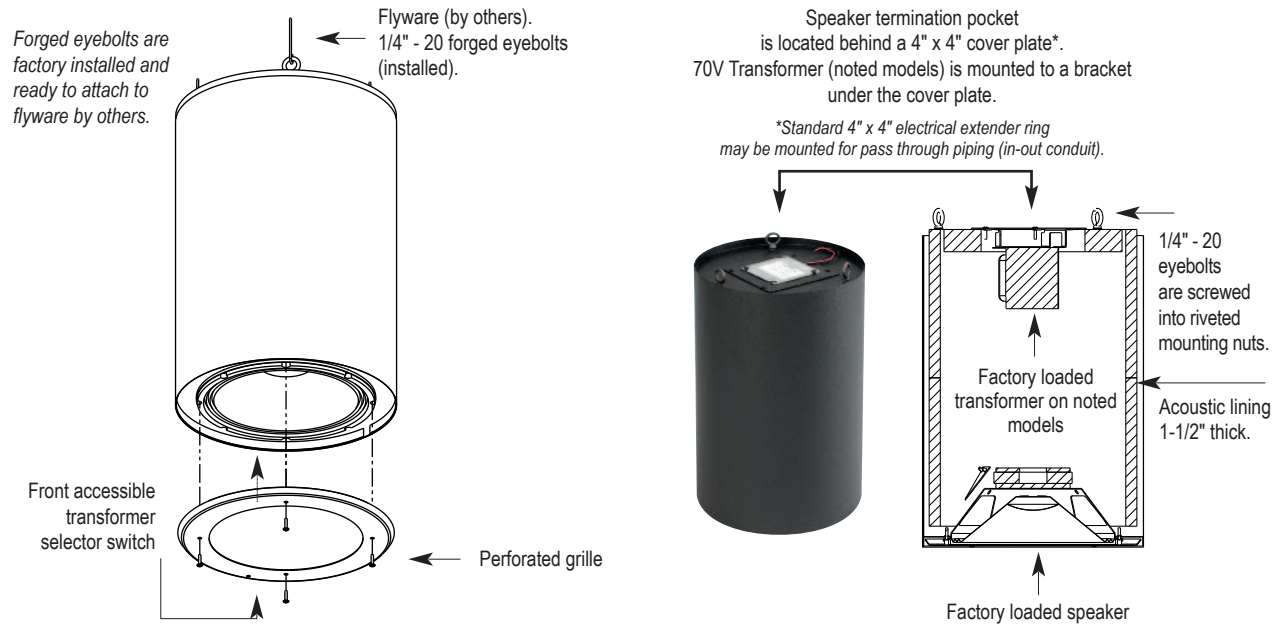

## IMC8P-series dimensions

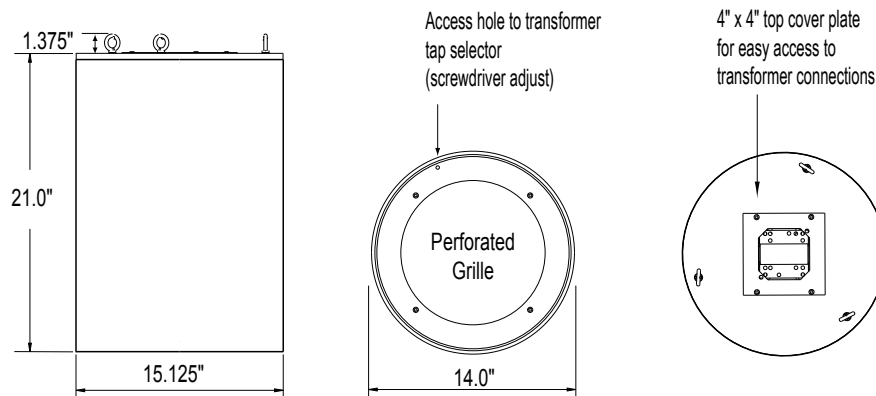

### Specifications - iMount IMC8P-series (measured in cylindrical enclosure with grille on)

Speaker Model	Speaker Rating	Speaker Size	Speaker Type	System Volume	System Dimensions	System Response	System Dispersion	System Sensitivity (SPL)
8P100	100W	8" (8 ohm)	Direct radiator LF Coax. compression HF	2 cu.ft.	21"H x 15.125"Dia.	48Hz - 20kHz±9dB	90° conical @ 2000Hz -6dB	94dB Avg. @1W/1M 114 Max* @ 100W/1M

\*Maximum sensitivity is calculated based on the power rating and measured sensitivity.

### Transformer Details (for Models with 70V transformer)

Transformer Model	Primary Voltage	Power Rating	Primary Taps	Secondary Impedance	Core Size	Insertion Loss	Frequency Response
TLS10070*	70V	100W	100, 64, 32, 16W	8, 4 Ohms	1.375" x 1.75"	.6dB	20Hz-20kHz ±1dB
TLS3270*	70V	32W	32, 16, 8W	8, 4 Ohms	1.25" x 1.25"	.6dB	20Hz-20kHz ±1dB

\*TLS Series is Lowell's 20/20 AudioVision transformer series with true 20Hz - 20kHz performance for full fidelity audio in distributed applications.

# iMount™ 100W Speaker System

## Test Methodology

Lowell iMount™ Systems are thoroughly tested to provide specifiers and contractors with solid, accurate data. Performance tests are conducted on randomly selected final production assemblies. Test equipment includes the GoldLine TEF-20 analyzer. The power handling capability is based on EIA Standard RS-426B. Frequency Response data is provided in two ways: Nominal - which is the generally usable response range and Limited Bandwidth - (defined by  $\pm$  dB) which is useful in predictive engineering calculations. Average Sensitivity (SPL), as documented here, is a computer calculation of the octave-weighted average over the entire engineering bandwidth as shown in the frequency response ( $\pm$  dB). Maximum SPL is calculated based on the power rating and the measured sensitivity.

Dispersion Angle is defined as the angle of coverage that is no more than 6dB down from the on-axis value averaged over the 2000 Hz octave band. Since speech intelligibility is very dependent upon the 2000 Hz octave, this specification is quite useful in designing paging systems that provide even coverage and intelligibility. The polar graphs illustrate how the system will perform when hung in free space (360°). Detailed specifications on the specified driver used in an iMount™ system are also available on the Lowell website at [www.lowellmfg.com](http://www.lowellmfg.com). Driver specification sheets are located in the speaker driver section.

## SPL vs. Frequency

1W/1M with grille on

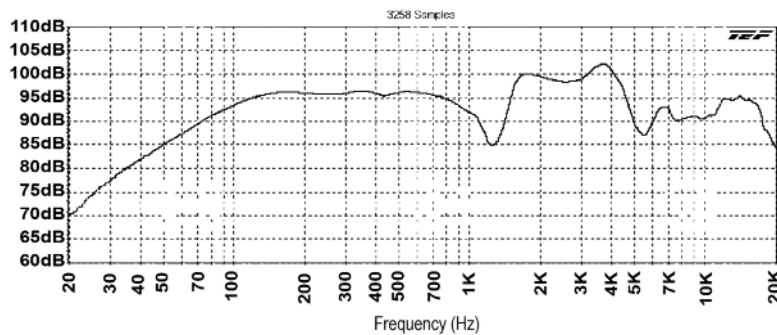

## Impedance

2 cu.ft. system - 1W/1M with grille on

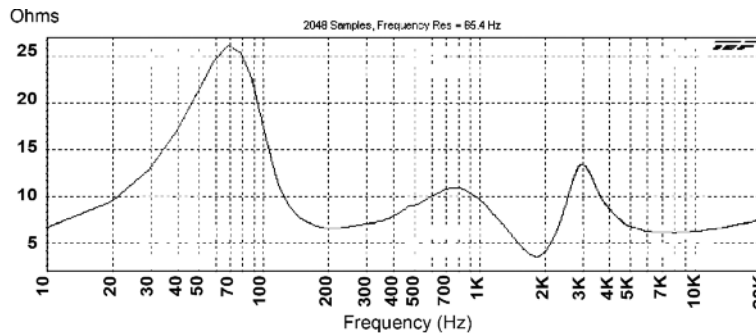

## Polar Data

2 cu.ft. system - 1W/1M with grille on

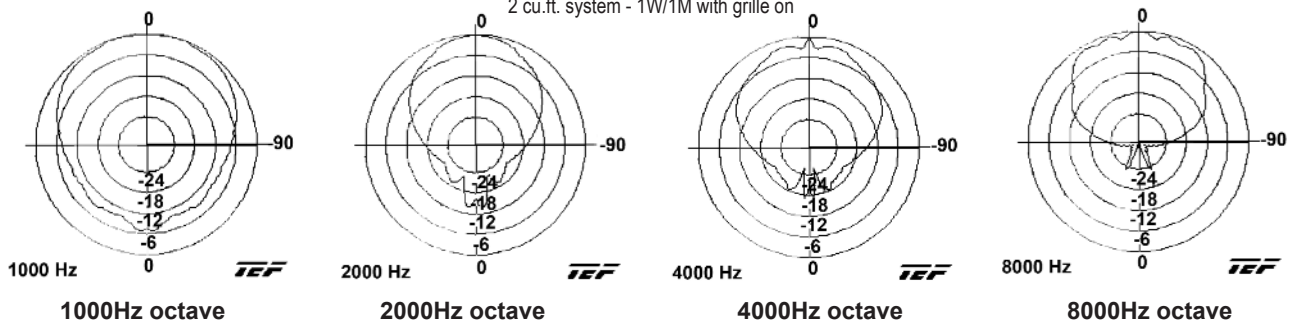

# iMount™ 100W Speaker System

## Installation

The iMount cylindrical systems are designed to mount using the installed forged eyebolts and flyware (by others) in an open area. **Mounting Note:** The system must be mounted in accordance with local, state, federal, and industry regulations. It is the owner and/or user's responsibility to evaluate the reliability of any rigging/support method for their application. Rigging/installation should be carried out only by experienced professionals.

### Hanging method - suspended by forged eyebolts (IMC Series)

The contractor shall employ the services of a qualified certified rigger for the installation of this product and only load-rated hardware with a design factor of at least X5 should be used to suspend this product. The rigging system design is solely the responsibility of the installing contractor and the rigging design should be reviewed and certified by a professional structural engineer.

### Typical Wiring Method

Remove the 4" x 4" cover plate located on the rear of the speaker system. Remove the knockout plug in the plate and install a UL Listed conduit connector or cable clamp as appropriate. Connect the field signal wiring to the two conductors sticking out of the rear of the speaker system. Red is positive, black is negative. Push the connections and all excess wire into the speaker system and to one side of the transformer bracket. Reattach the cover plate to the rear of the speaker system. (See Figure. 1)

### Alternate wiring method - Use when in/out conduit is specified.

Remove the 4" x 4" cover plate located on the rear of the speaker system. Install an approved 4x4 extender ring, attaching it to the mounting holes where the cover plate was secured. Select wiring entry positions on the side of the extender ring and remove the corresponding knockouts. Install conduit connectors and secure conduit. Make wiring connections (Red-positive, black-negative). If the unit is being installed above a ceiling, push the wiring and connectors into the speaker system and to one side of the transformer bracket. (See Figure. 2)

### Transformer settings

After the speaker system is installed, remove the grille on the IMC Series. Next to the speaker cone, locate the screwdriver adjustable speaker tap selector (See Figure 3). **Important! Before turning on power,** use a screwdriver to turn the switch counter-clockwise to the lowest tap setting. Then turn the switch incrementally clockwise to the desired tap setting. Starting at the lowest position avoids accidental selection of the wrong tap. The selector switch will still be accessible through a hole in the grille after the grille has been mounted.

### Grille installation.

Mount the perforated grille over the speaker cone using 8-32 screws provided.

**Figure 1**

Typical Wiring Diagram

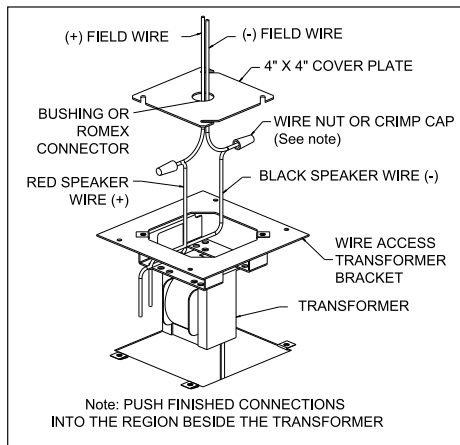

**Figure 2**

Wiring Diagram when in/out conduit is specified.

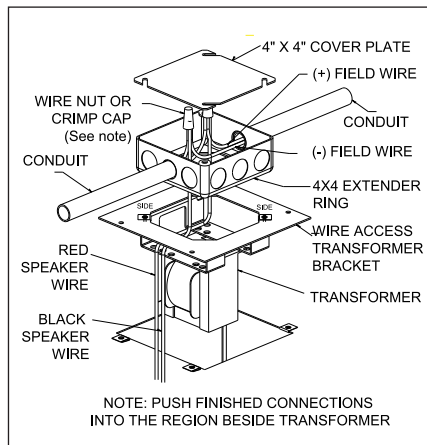

**Figure 3**

Transformer Power Tap Settings

