

iMount™ 50W Speaker System

Description

iMount™ Speaker systems provide specifiers and systems integrators with versatile packaged solutions for high performance suspended speaker installations. Model Group IM8A features Lowell's 8" speaker Model 8A50 (50W) mounted in to a rectangular 2 cu.ft. acoustic enclosure with installed 1/4" - 20 forged eyebolts and square architectural grille in black (SB) or white (SW). Ready-to-install systems feature externally accessible speaker connections and 20/20 AudioVision™ transformer (noted models) for superior music fidelity in distributed applications. Systems are ideal for upscale restaurants, lounges, hotel lobbies, department stores, and boutiques where a positive consumer listening experience is key to customer satisfaction. Systems are shipped one per carton with a steel plate mounted over the speaker to protect it during shipping and installation.

Features:

- Packaged solution for high performance suspended speaker installations.
- 50W system reproduces music with exceptional quality for improved customer satisfaction.
- Installation is fast and easy with premounted eyebolts and externally accessible connections.
- Optional 20/20 AudioVision™ transformer for distributed applications.

System Components:

The 8-ohm 8A50 speaker features a large 20oz. magnet coupled with a 1.4" copper voice coil driving a polypropylene cone with half-roll rubber surround for long cone travel and good edge damping. The post-mounted tweeter is a 1-inch balanced drive dome protected by Ferrofluid and a first order high pass filter for excellent power handling, low distortion and smooth musical sound. The speaker is mounted into the enclosure with terminations accessible through a top mounted 4" x 4" cover plate.

Transformer Model TLS3270 is included in select models. This 70V-32W transformer features a front mounted tap selector switch with convenient access under the grille. This high performance transformer is part of Lowell's exclusive 20/20 AudioVision™ Series offering true 20Hz - 20kHz performance. *Note: 20/20 AudioVision™ Transformers have full frequency response and high power handling which allows the speaker to operate at full potential while providing a stable load to the amplifier. The resulting benefit is that 20/20 AudioVision™ Transformers allow a distributed speaker system to sound imperceptibly the same as a "transformerless" direct to voice coil system with the advantages of easier wiring layout, less expensive wire, and reduced labor cost.*

Enclosure is precision-formed steel with anti-vibration ribs, Soundstop Board™, 1-1/2" thick premium acoustic lining, and forged 1/4" - 20 eyebolts screwed into riveted mounting nuts for secure suspended installation using flyware by others.

Architectural grilles are perforated steel in square black (SB) or square white (SW). Black grilles are preferred in open ceiling installations as they blend in with the black enclosure; white grilles are ideal for applications where the speaker is suspended into a tile, sheetrock or plaster ceiling. Grilles and enclosures are finished in durable powder epoxy.



IM8A-series 2 cu.ft. Assembly

Each assembly includes:

- 2cu.ft. acoustic enclosure
- 50W speaker Model 8A50 (8-ohm)
- 70V-32W transformer Model TLS3270 (noted models)
- Architectural grille in black (SB) or white (SW)
- 1/4 x 20 forged eyebolts
- Wiring terminated through a 4" x 4" flush cover plate



Speaker
8A50



Transformer
(noted models only)

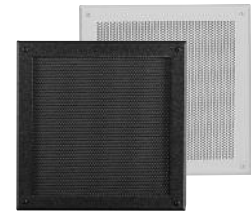

Grille
Black or White

A&E Specifications

The speaker for suspended installation shall be Lowell iMount system Model IM8A-____ with 8" 50W speaker Model 8A50 mounted into an acoustic enclosure with a volume of 2 cu.ft., installed forged eyebolts, and square steel architectural grille painted____(black, white). Frequency response of the iMount™ system shall be 53Hz - 7.97kHz +6dB with an average sensitivity of 90.5dB. Dispersion shall be 100 degrees @ 2000Hz measured 6dB down. Overall dimensions shall be 8"H x 18"W x 24"L. System speaker Model 8A50 shall have an 8-inch polypropylene cone, 20oz magnet, 1.4" copper voice coil, and a 1" balance-drive dome tweeter with a built-in electrical crossover network. The crossover frequency shall be at 4000Hz with a 1st order high-pass filter. For distributed applications, the speaker shall include a wired 70V 32W transformer Model TLS3270. Transformer tap selections shall be adjustable on the front of the assembly. System enclosure shall be welded steel construction with anti-vibration ribs, Soundstop Board™, 1-1/2" thick acoustic lining. It shall have forged 1/4" - 20 eyebolts screwed into riveted mounting nuts for suspended installation using flyware by others.

Model No.	Description	Volume	Speaker	Transformer (70V)	Grille	Mtg Hardware	Weight lbs.
IM8A-2SB	iMount 50W Packaged Speaker System	2 cu.ft.	8A50	---	Square black	(4) 1/4" - 20 forged eyebolts	25
IM8A-2SW	iMount 50W Packaged Speaker System	2 cu.ft.	8A50	---	Square white	(4) 1/4" - 20 forged eyebolts	25
IM8A-TS32-2SB	iMount 50W Packaged Speaker System	2 cu.ft.	8A50	TLS3270	Square black	(4) 1/4" - 20 forged eyebolts	33
IM8A-TS32-2SW	iMount 50W Packaged Speaker System	2 cu.ft.	8A50	TLS3270	Square white	(4) 1/4" - 20 forged eyebolts	33

iMount™ 50W Speaker System

IM8A-series ship wired and ready for installation!

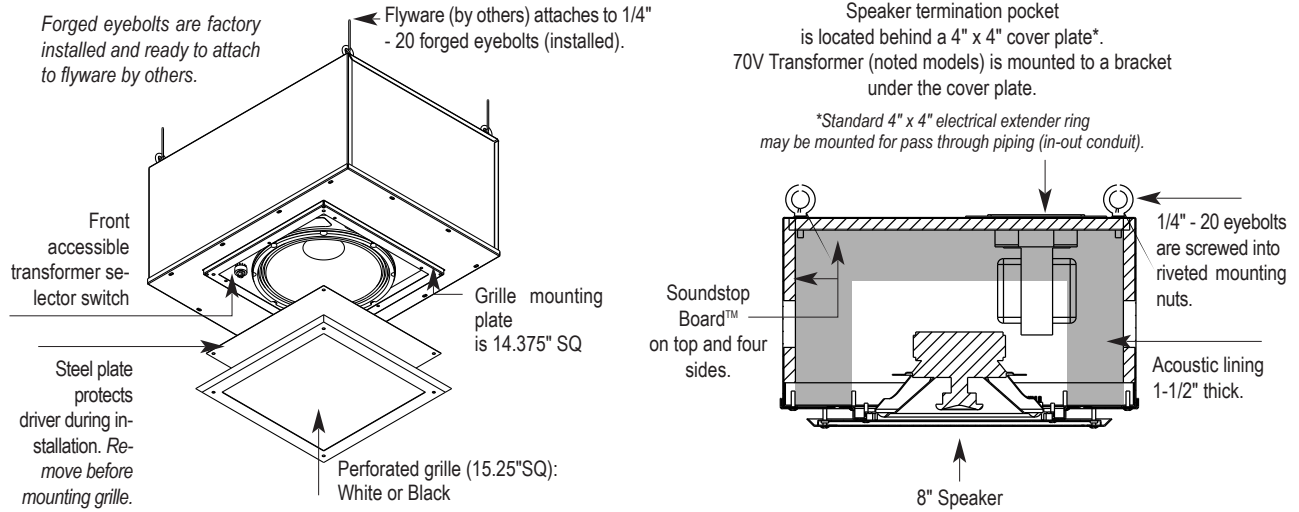

IM8A-series dimensions

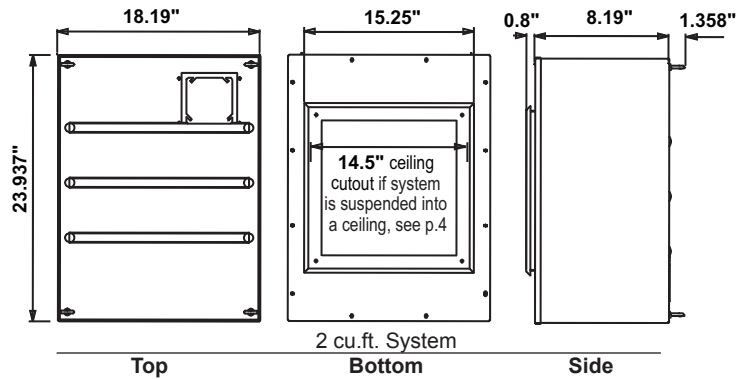

Specifications - iMount IM8A-series (measured with grille on)

Speaker Model	Speaker Rating	Speaker Size	Speaker Type	System Volume	System Dimensions	System Response	System Dispersion	System Sensitivity (SPL)
8A50	50W	8\" (8 ohm)	Coaxial	2 cu.ft.	8\"H x 18\"W x 24\"L	53Hz - 7.97kHz±6dB	100° conical @ 2000Hz -6dB	90.5dB Avg. @ 1W/1M 107.5 Max* @ 50W/1M

*Maximum sensitivity is calculated based on the power rating and measured sensitivity.

Transformer Details (for Models with 70V transformer)

Transformer Model	Primary Voltage	Power Rating	Primary Taps	Secondary Impedance	Core Size	Insertion Loss	Frequency Response
TLS3270*	70V	32W	32, 16, 8W	8, 4 Ohms	1.25\" x 1.25\"	.6dB	20Hz-20kHz +1dB

*TLS Series is Lowell's 20/20 AudioVision transformer series with true 20Hz - 20kHz performance for full fidelity audio in distributed applications.

iMount™ 50W Speaker System

Test Methodology

Lowell iMount™ Systems are thoroughly tested to provide specifiers and contractors with solid, accurate data. Performance tests are conducted on randomly selected final production assemblies. Test equipment includes the GoldLine TEF-20 analyzer. The power handling capability is based on EIA Standard RS-426B. Frequency Response data is provided in two ways: Nominal - which is the generally usable response range and Limited Bandwidth - (defined by \pm dB) which is useful in predictive engineering calculations. Average Sensitivity (SPL), as documented here, is a computer calculation of the octave-weighted average over the entire engineering bandwidth as shown in the frequency response (\pm dB). Maximum SPL is calculated based on the power rating and the measured sensitivity.

Dispersion Angle is defined as the angle of coverage that is no more than 6dB down from the on-axis value averaged over the 2000 Hz octave band. Since speech intelligibility is very dependent upon the 2000 Hz octave, this specification is quite useful in designing paging systems that provide even coverage and intelligibility. The polar graphs illustrate how the system will perform when hung in free space (360°). Detailed specifications on the specified driver used in an iMount™ system are also available on the Lowell website at www.lowellmfg.com. Driver specification sheets are located in the speaker driver section.

SPL vs. Frequency

(2 cu.ft. system - 1W/1M with grille on)

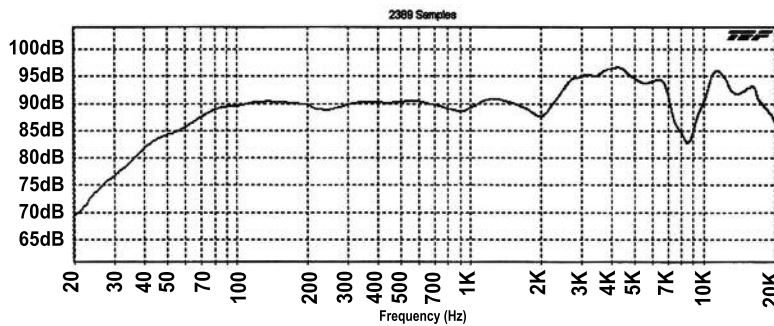

Impedance

(2 cu.ft. system - 1W/1M with grille on)

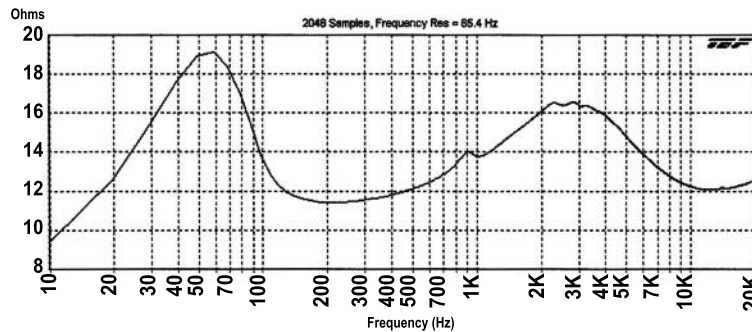

Polar Data 3600

(2 cu.ft. system - 1W/1M with grille on)

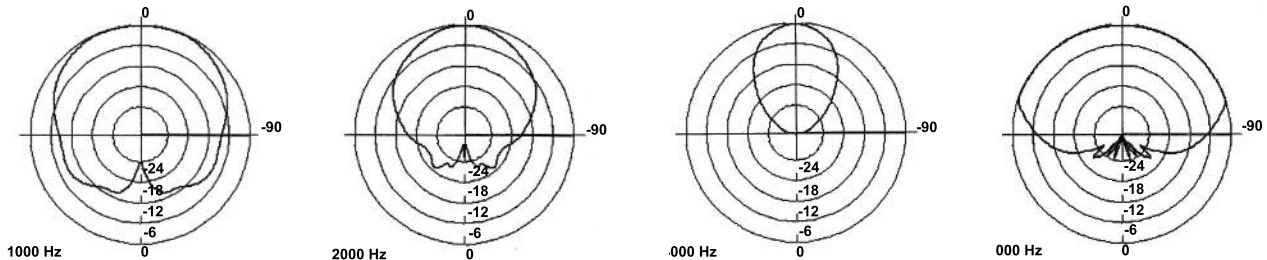

iMount™ 50W Speaker System

Installation

Mounting Note: For all methods, it is important to note that the speaker system must be mounted in accordance with local, state, federal, and industry regulations. It is the owner and/or user's responsibility to evaluate the reliability of any rigging/support method for their application. Rigging/installation should be carried out only by experienced professionals.

There are three basic ways to install an iMount Model Group IM8A speaker system. 1) Hang the system using the installed forged eyebolts and flyware (by others) so that it is suspended in an open area (see figure 1). 2) Hang the system using the installed forged eyebolts and flyware (by others) so that it is suspended into a rigid or tile ceiling (see Figure 2). 3) Hard mount or "rear anchor" the system to structural members or unistrut using bolts by others (illustration not shown).

Typical Wiring Method

Remove the 4" x 4" cover plate located on the rear of the speaker system. Remove the knockout plug in the plate and install a UL Listed conduit connector or cable clamp as appropriate. Connect the field signal wiring to the two conductors sticking out of the rear of the speaker system. Red is positive, black is negative. Push the connections and all excess wire into the speaker system and to one side of the transformer bracket. Reattach the cover plate to the rear of the speaker system. (See Figure 3)

Alternate wiring method - Use when in/out conduit is specified.

Remove the 4" x 4" cover plate located on the rear of the speaker system. Install an approved 4x4 extender ring, attaching it to the mounting holes where the cover plate was secured. Select wiring entry positions on the side of the extender ring and remove corresponding knockouts. Install conduit connectors and secure conduit. Make wiring connections (Red-positive, black-negative). If the unit is being installed above a ceiling, push the wiring and connectors into the speaker system and to one side of the transformer bracket. (See Figure 4)

Transformer settings

After the speaker system is installed, locate the screwdriver adjustable speaker tap selector by the speaker cone (See Figure 5). **Important! Before turning on power**, use a screwdriver to turn the switch counter-clockwise to the lowest tap setting. Then turn the switch incrementally clockwise to the desired tap setting. Starting at the lowest position avoids accidental selection of the wrong tap. The selector switch will be covered when the grille is mounted.

Grille installation.

Mount the perforated grille over the speaker cone using 8-32 screws provided. Note: the grille installs into the same holes used by the cover plate that protected the speaker during shipping. Discard cover plate.

Figure 1

Suspended in an open area (360 degree full space mounting).

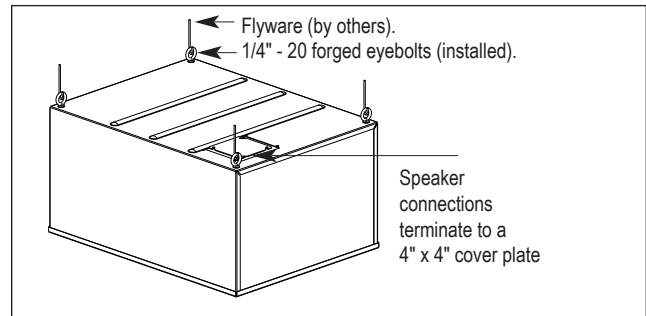

Figure 2

Suspended into a rigid or tile ceiling (180 degree half space mounting).

Note: load support is on eyebolts not ceiling.

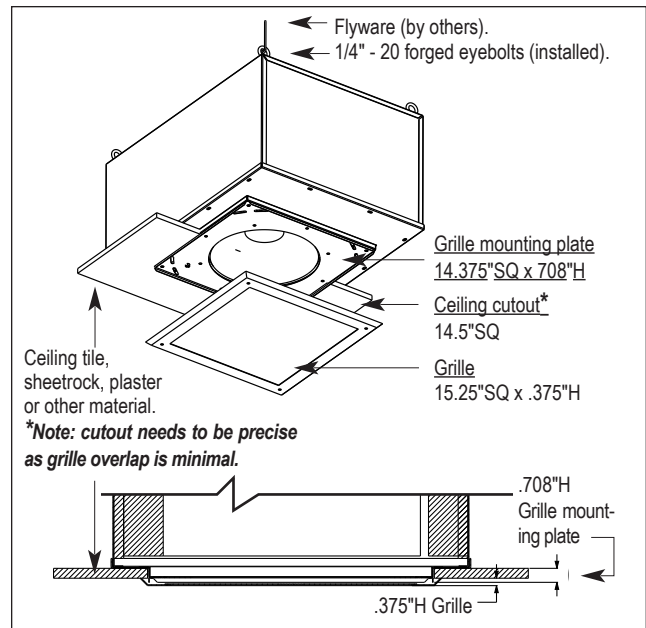

Figure 3

Typical Wiring Diagram

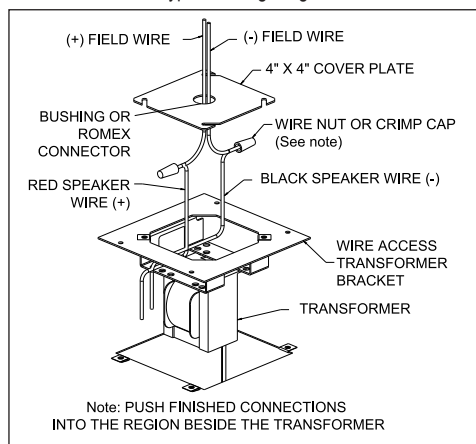

Figure 4

Wiring Diagram when in/out conduit is specified.

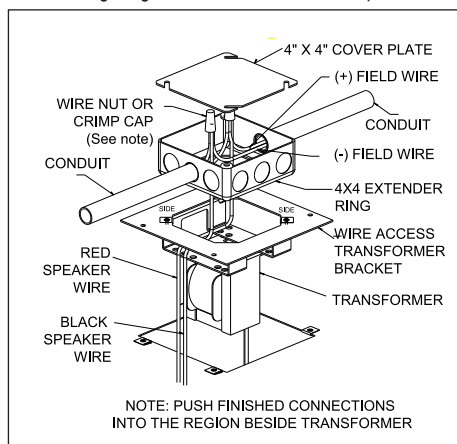

Figure 5

Transformer Power Tap Settings

