

Model series: LT-410

Lay-in Tile Packaged Speaker System (music / paging, 4" speaker)

Description:

The LT-series speaker assembly provides easy installation in suspended tile ceiling applications. A selection of speakers, transformers and backboxes allows integrators to achieve various performance levels required for music or commercial paging in lounges, restaurants, lobbies, retail stores and similar venues. The LT is shipped ready-to-install and does not require speaker cut-outs in ceiling tile. **1'x2' Assembly:** is supported by the T-Bar grid and includes an integral T-Bar support (US patent no's. 7,120,269; D467,579 and 7,643,647) for fast installation when replacing half of a non-regular 2'x2' ceiling tile or one-fourth of a non-regular 2'x4' ceiling tile. System includes a speaker assembly with choice of two transformers mounted to a 1'x2' subplate with fine-perforation pattern grille, integral T-Bar, and value backbox.

System Features:

- Speaker: model JR410 is a 15W high-compliance speaker with 10 oz. magnet for commercial paging and background music.
- Transformer: 2 models
 - TLM572: 70/25V transformer with taps at 0.25, 0.5, 1, 2, 5 W
 - TLM870: 70V transformer with taps at 1, 2, 4, 8 W
- Grille: fine-perforation pattern grille, designed to provide maximum free-air space for excellent sound transmission, while maintaining an unobtrusive appearance in new or existing tile ceilings. The 1'x2' grille includes an integral two-foot T-bar to support neighboring non-regular ceiling tile.
- Backbox: 0.147 cu.ft. value backbox protects speaker assembly. Black powder epoxy finish. Speaker leads exit through a metal clamp for fast connection. (Splice connecting wires, push them inside the enclosure and tighten the clamp.)

A&E Specifications:

The speaker system for suspended tile ceilings shall be Lowell LT-series Model _____ with grille size 1'x2'. The 1'x2' system shall replace half of a non-regular 2'x2' ceiling tile or one-fourth of a non-regular 2'x4' ceiling tile and shall include an integral T-Bar to support the adjacent ceiling tile. Each system shall include a factory-mounted speaker mounted to a subplate with a fine perforation pattern steel grille finished in white powder epoxy. The speaker shall be 4" with a power rating of _____. It shall have a magnet weight of 10 ozs., frequency response of _____ and a sensitivity of _____ measured 1W/1M. System shall include a factory-mounted steel backbox with a volume of 0.147 cu.ft. and finished in black powder epoxy. System shall also include a _____ W transformer with primary taps at _____.

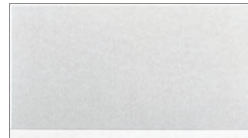
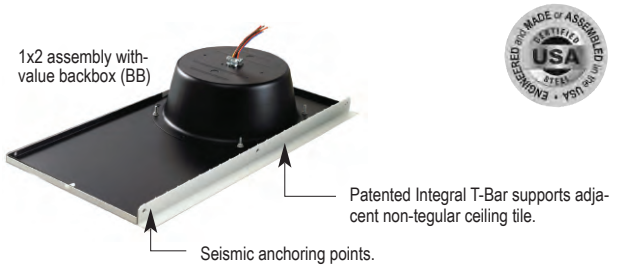

Fine-perforation pattern grille is designed to blend with tile ceilings.



JR410



TLM572



TLM870

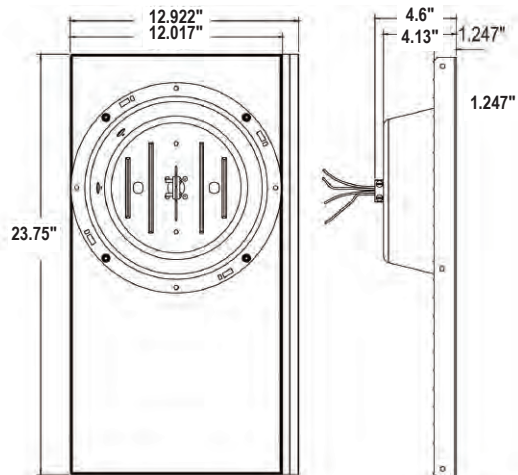

Speaker Specs (measured half space)												
Speaker Model No.	Size	Power Rating	Type	Ceramic Magnet	Frequency Response	Dispersion (octave avg.)	Voice Coil Impedance	Voice Coil Diameter	Sensitivity 1W / 1M	Max SPL*	Depth (w/o xfmr)	Weight (w/o xfmr)
JR410	4"	15W	High compliance	10 oz.	100Hz - 14kHz +6dB 100Hz - 16kHz Nominal	170° @ 2000Hz -6dB	8 Ohms	1"	91dB Avg		2.08"	1.7lbs.

*Calculated value 1M @ speaker maximum power. Complete information including frequency and polar data is available on the speaker spec sheet.

Model No.	Description	Speaker	Transformer	Taps	Backbox	Grille
LT-410-72-BB	1x2 LT Speaker System	JR410 (15W)	TLM572	70/25V: 0.25, 0.5, 1, 2, 5 W	8XD4 (0.147 cu.ft.)	White
LT-410-870-BB	1x2 LT Speaker System	JR410 (15W)	TLM870	70V: 1, 2, 4, 8 W	8XD4 (0.147 cu.ft.)	White

Spec. No. **1048**
(rev. 12.07.10)
pg. 1 of 1

©2010 Lowell Manufacturing Company, 100 Ingram Dr., Pacific MO 63069. Phone-800.325.9660 Fax-636.257.6606. Lowell makes every effort to provide accurate information while reserving the right to change specifications and/or improve manufacturing methods without notification. (lowellmfg.com)

