

Quality Features

- Fixed position writing surface on a 2 RU panel provides a surface area of 17.375"W x 15"D.
- Ships fully assembled for labor saving installation.
- Attaches easily to the front rails on 19"W EIA racks.
- Woodgrain laminate provides a smooth and attractive surface.
- Sturdy 16 gauge US steel frame supports 30lbs.
- Requires panel mounting hardware (see page 2).



L16-3

Description

Lowell writing surface Model L16-3 provides a fixed position shelf for writing applications or for supporting items such as small keyboards and controls that do not exceed 30 pounds. Sturdy accessory ships fully assembled for fast and trouble-free jobsite installation.

Stationary writing surface utilizes 2RU of panel mounting space in a 19"W EIA rack and extends out 15". It attaches to the front rails using four 10-32 panel mounting screws (order separately, see page 2). Construction of the writing surface frame assembly is 16 gauge US steel finished in smooth black powder epoxy. The writing surface top is an attractive woodgrain laminate over particle board. It measures 5/16" thick and is secured to the frame with screws.

A & E Specifications

The writing surface for fixed use in 19"W EIA racks shall be Lowell Model L16-3. The writing surface shall have a rack panel space height of 3.5" (2RU). It shall measure 19"W with a writing surface area of 17.375"W x 15"D. It shall be capable of supporting 30 lbs. The writing shelf frame shall be constructed of 16 gauge US steel and finished in a black powder epoxy. The top shall be woodgrain laminate covered particle board and shall be screw mounted to the frame. The writing surface shall ship factory assembled and mount to EIA rails using 10-32 panel mounting hardware (order separately).

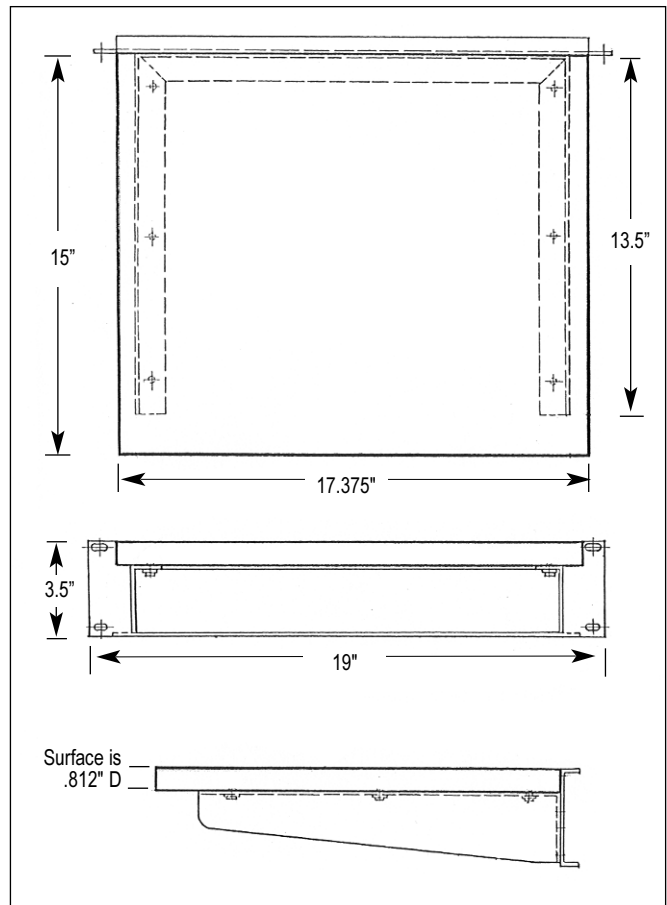

L16-3 Dimensions

19"W WRITING SHELF SPECIFICATIONS

Model	Description	Panel Space (inches)	Rack Space (Rack Units)	Surface Width	Surface Depth	Weight	Load Rating	Requires (order separately)
L16-3	Fixed writing surface assembly	3.5"	2 RU	17.375"	15"	12 lbs	30 lbs.	(4) 10-32 screws

Panel Mounting Screws (order separately)

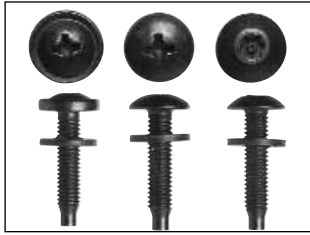

RSP Phillips Finish Head
RS Phillips Truss Head
RSV Torx® Star Post Head



RSP-500 / RS-500 Jars

ALL screws have 5.1 hardness and include PilotPoint™ tip and captive washer!

Model	Description	Quantity
RSP-25	Hdwr phillips finish head pilot pt w washers Blk 10-32x.875	25 pc bag
RSP-100	Hdwr phillips finish head pilot pt w washers Blk 10-32x.875	100 pc bag
RSP-500	Hdwr phillips finish head pilot pt w washers Blk 10-32x.875	500 pc jar
RS-25	Hdwr phillips truss head pilot pt w washers Blk 10-32x.875	25 pc bag
RS-100	Hdwr phillips truss head pilot pt w washers Blk 10-32x.875	100 pc bag
RS-500	Hdwr phillips truss head pilot pt w washers Blk 10-32x.875	500 pc jar
RSR-50	Hdwr robertson SQ- head pilot pt w washers Blk 10-32x.875	50 pc bag
RSR-BIT	Hdwr torx pin drive bit for RSR Series screws	1 Qty
RSV-50	Hdwr torx star post security pilot pt w washers Blk 10-32x.875	50 pc bag
RSV-BIT	Hdwr torx pin drive bit for RSV Series screws	1 Qty

NEW RSR Robertson square head available!

Panel Space Reference Guide per EIA Standards

Accessory Panel Space Height - Nominal (Inches) (Rack Units - RU)		Cabinet Panel Space Opening - Actual (Inches)	EIA Holes Used / Covered per Mounting Rail (Spaced .625" - .625" - .5")
1.75	1	1.875	3
3.50	2	3.625	6
5.25	3	5.375	9
7.00	4	7.125	12
8.75	5	8.875	15
10.50	6	10.625	18
12.25	7	12.375	21
14.00	8	14.125	24
15.75	9	15.875	27
17.50	10	17.625	30
19.25	11	19.375	33
21.00	12	21.125	36
22.75	13	22.875	39
24.50	14	24.625	42
26.25	15	26.375	45
28.00	16	28.125	48
29.75	17	29.875	51
31.50	18	31.625	54
33.25	19	33.375	57
35.00	20	35.125	60
36.75	21	36.875	63
38.50	22	38.625	66
40.25	23	40.375	69
42.00	24	42.125	72
43.75	25	43.875	75
45.50	26	45.625	78
47.25	27	47.375	81
49.00	28	49.125	84
50.75	29	50.875	87
52.50	30	52.625	90
54.25	31	54.375	93
56.00	32	56.125	96
57.75	33	57.875	99
59.50	34	59.625	102
61.25	35	61.375	105
63.00	36	63.125	108
64.75	37	64.875	111
66.50	38	66.625	114
68.25	39	68.375	117
70.00	40	70.125	120
71.75	41	71.625	123
73.50	42	73.625	126
75.25	43	75.375	129
77.00	44	77.125	132

Open Frame
Floor

Solid Side
Floor &
Desk

Wallmount
Surface &
Recessed

Panels &
Accessories

Thermal &
Wire Mngmt

19W Shelves - Writing