

Features

- Rugged 16-gauge US steel construction.
- Supports up to 50 lbs.
- Choice of 10" or 14" depth.
- Choice of 1-4RU panel space heights.
- Finished in durable black powder epoxy.

Description

Lowell Series L15 utility shelves are solid general purpose accessories that mount 19"W racks to provide sturdy support for non-rackmount equipment such as consumer electronics, power supplies, and chassis style components of all kinds. Shelves are precision formed from a single piece of 16 gauge US steel and include a front and rear flange that is .438"H to provide added strength and to help retain shelved items. Assemblies are finished in smooth black powder epoxy.

L15 Series shelves for 19"W cabinets are offered in 1-4RU sizes and depths of 10" (L15-110, L15-310, L15-510, L15-710) or 14" (L15-114, L15-314, L15-514, L15-714). All shelves mount to the front mounting rails of E.I.A. standard 19"W racks and have a conservative load rating of 50 lbs.

A & E Specifications

The shelf for 19"W rackmount use shall be Lowell 10"D Model _____ (L15-110, L15-310, L15-510, L15-710) or 14"D Model (L15-114, L15-314, L15-514, L15-714). Shelf shall have a panel space height of ____ (1RU, 2RU, 3RU, 4RU). It shall be fabricated of 16-gauge US steel and be capable of supporting up to 50 lbs. The shelf shall be finished in black powder epoxy.

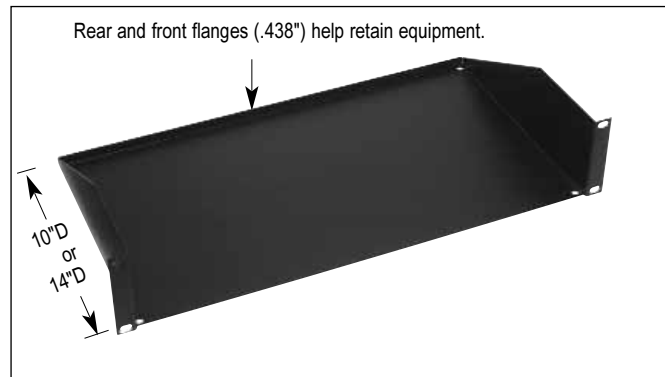

L15 Series (L15-110 shown)

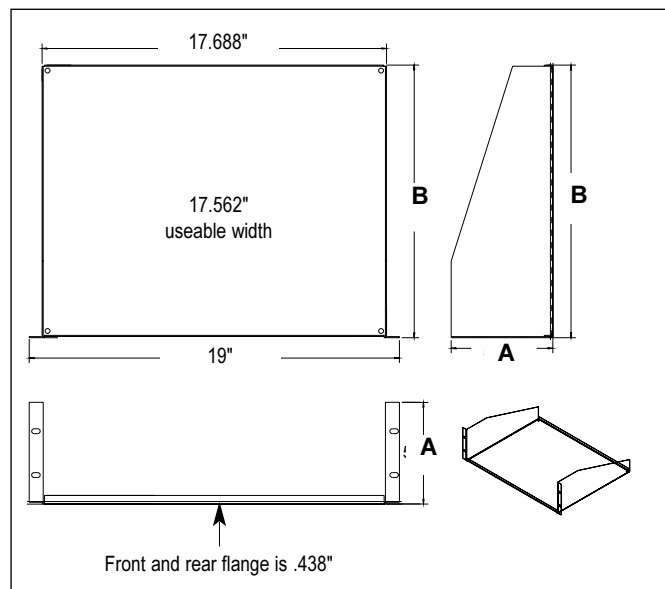

L15 Series Dimensions

19"W SHELF SPECIFICATIONS

Model	Description	Rack Units (A)	Panel Space (A)	Depth (B)	Useable Width	Weight	Load Rating
L15-110	Solid utility shelf, 16 gauge steel	1 RU	1.75"	10"	17.562"	4 lbs.	50 lbs.
L15-310*	Solid utility shelf, 16 gauge steel	2 RU	3.5"	10"	17.562"	5 lbs.	50 lbs.
L15-510	Solid utility shelf, 16 gauge steel	3 RU	5.25"	10"	17.562"	5.25 lbs.	50 lbs.
L15-710	Solid utility shelf, 16 gauge steel	4 RU	7"	10"	17.562"	6 lbs.	50 lbs.
L15-114	Solid utility shelf, 16 gauge steel	1 RU	1.75"	14"	17.562"	6 lbs.	50 lbs.
L15-314*	Solid utility shelf, 16 gauge steel	2 RU	3.5"	14"	17.562"	7 lbs.	50 lbs.
L15-514	Solid utility shelf, 16 gauge steel	3 RU	5.25"	14"	17.562"	7.25 lbs.	50 lbs.
L15-714	Solid utility shelf, 16 gauge steel	4 RU	7"	14"	17.562"	8 lbs.	50 lbs.

* 2RU Models are available in contractor friendly bulk cartons.

Panel Mounting Screws (order separately)

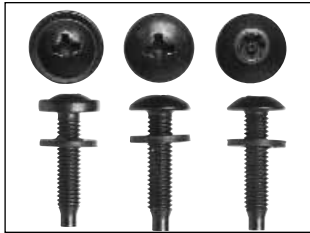

RSP Phillips Finish Head
RS Phillips Truss Head
RSV Torx® Star Post Head



RSP-500 / RS-500 Jars

ALL screws have 5.1 hardness and include PilotPoint™ tip and captive washer!

Model	Description	Quantity
RSP-25	Hdwr phillips finish head pilot pt w washers Blk 10-32x.875	25 pc bag
RSP-100	Hdwr phillips finish head pilot pt w washers Blk 10-32x.875	100 pc bag
RSP-500	Hdwr phillips finish head pilot pt w washers Blk 10-32x.875	500 pc jar
RS-25	Hdwr phillips truss head pilot pt w washers Blk 10-32x.875	25 pc bag
RS-100	Hdwr phillips truss head pilot pt w washers Blk 10-32x.875	100 pc bag
RS-500	Hdwr phillips truss head pilot pt w washers Blk 10-32x.875	500 pc jar
RSR-50	Hdwr robertson SQ- head pilot pt w washers Blk 10-32x.875	50 pc bag
RSR-BIT	Hdwr torx pin drive bit for RSR Series screws	1 Qty
RSV-50	Hdwr torx star post security pilot pt w washers Blk 10-32x.875	50 pc bag
RSV-BIT	Hdwr torx pin drive bit for RSV Series screws	1 Qty

NEW RSR Robertson square head available!

Panel Space Reference Guide per EIA Standards

Accessory Panel Space Height - Nominal (Inches) (Rack Units - RU)		Cabinet Panel Space Opening - Actual (Inches)	EIA Holes Used / Covered per Mounting Rail (Spaced .625" - .625" - .5")
1.75	1	1.875	3
3.50	2	3.625	6
5.25	3	5.375	9
7.00	4	7.125	12
8.75	5	8.875	15
10.50	6	10.625	18
12.25	7	12.375	21
14.00	8	14.125	24
15.75	9	15.875	27
17.50	10	17.625	30
19.25	11	19.375	33
21.00	12	21.125	36
22.75	13	22.875	39
24.50	14	24.625	42
26.25	15	26.375	45
28.00	16	28.125	48
29.75	17	29.875	51
31.50	18	31.625	54
33.25	19	33.375	57
35.00	20	35.125	60
36.75	21	36.875	63
38.50	22	38.625	66
40.25	23	40.375	69
42.00	24	42.125	72
43.75	25	43.875	75
45.50	26	45.625	78
47.25	27	47.375	81
49.00	28	49.125	84
50.75	29	50.875	87
52.50	30	52.625	90
54.25	31	54.375	93
56.00	32	56.125	96
57.75	33	57.875	99
59.50	34	59.625	102
61.25	35	61.375	105
63.00	36	63.125	108
64.75	37	64.875	111
66.50	38	66.625	114
68.25	39	68.375	117
70.00	40	70.125	120
71.75	41	71.625	123
73.50	42	73.625	126
75.25	43	75.375	129
77.00	44	77.125	132

Open Frame
Floor

Solid Side
Floor &
Desk

Wallmount
Surface &
Recessed

Panels &
Accessories

Thermal &
Wire Mngmt